

Proteoglycans, Hyaluronan & Glycosaminoglycans

- **Glycoprotein vs. Proteoglycan**
- **Glycosaminoglycan (GAG) classes**
 - Mucopolysaccharides (aka GAGs)
- **GAG synthesis locations**
- **Proteoglycan classes**
- **GAG degradation**
 - Osteoarthritis
 - Mucopolysaccharidoses

Glycoproteins vs. Proteoglycans

Parameter	Glycoprotein	Proteoglycan
Glycoconjugates synthesized on a core protein	Yes	Yes
Size of its glycoconjugates	Small (< 10 kDa; typically 3-5 kDa)	Large (15-70 kDa; excludes HA)
Presence of hexosamines	Yes	Yes
Presence of uronic acids	Few	Many
Presence of sulfate groups	Few	Many























































































Third Edition of *Essentials of Glycobiology*—Appendix 1B: Symbol Nomenclature for Glycans (SNFG)

History and Citation:

Symbol Nomenclature for Graphical Representation of Glycans, *Glycobiology* 25: 1323-1324, 2015. [Citation link](#) (PMID [26543186](#)).

Table 1. Monosaccharide symbol nomenclature

June 5, 2017

SHAPE	White (Generic)	Blue	Green	Yellow	Orange	Pink	Purple	Light Blue	Brown	Red
Filled Circle	Hexose 	Glc 	Man 	Gal 	Gul 	Alt 	All 	Tal 	Ido 	
Filled Square	HexNAc 	GlcNAc 	ManNAc 	GalNAc 	GulNAc 	AltNAc 	AllNAc 	TalNAc 	IdoNAc 	
Crossed Square	Hexosamine 	GlcN 	ManN 	GalN 	GulN 	AltN 	AllN 	TalN 	IdoN 	
Divided Diamond	Hexuronate 	GlcA 	ManA 	GalA 	GulA 	AltA 	AllA 	TalA 	IdoA 	
Filled Triangle	Deoxyhexose 	Qui 	Rha 		6dGul 	6dAlt 		6dTal 		Fuc 
Divided Triangle	DeoxyhexNAc 	QuiNAc 	RhaNAc 			6dAltNAc 		6dTalNAc 		FucNAc 
Flat Rectangle	Di-deoxyhexose 	Oli 	Tyv 		Abe 	Par 	Dig 	Col 		
Filled Star	Pentose 		Ara 	Lyx 	Xyl 	Rib 				
Filled Diamond	Deoxynonulosonate 		Kdn 				Neu5Ac 	Neu5Gc 	Neu 	Sia 
Flat Diamond	Di-deoxynonulosonate 		Pse 	Leg 		Aci 		4eLeg 		
Flat Hexagon	Unknown 	Bac 	LDmanHep 	Kdo 	Dha 	DDmanHep 	MurNAc 	MurNGc 	Mur 	
Pentagon	Assigned 	Api 	Fru 	Tag 	Sor 	Psi 				

When viewed in presentation/slide-show mode, clicking individual monosaccharide names or symbols will lead to corresponding PubChem page. Right/Control click to copy a symbol, along with the embedded PubChem URL, which will also remain when pasting into some word-processing applications.

Proteoglycans

GAG chains

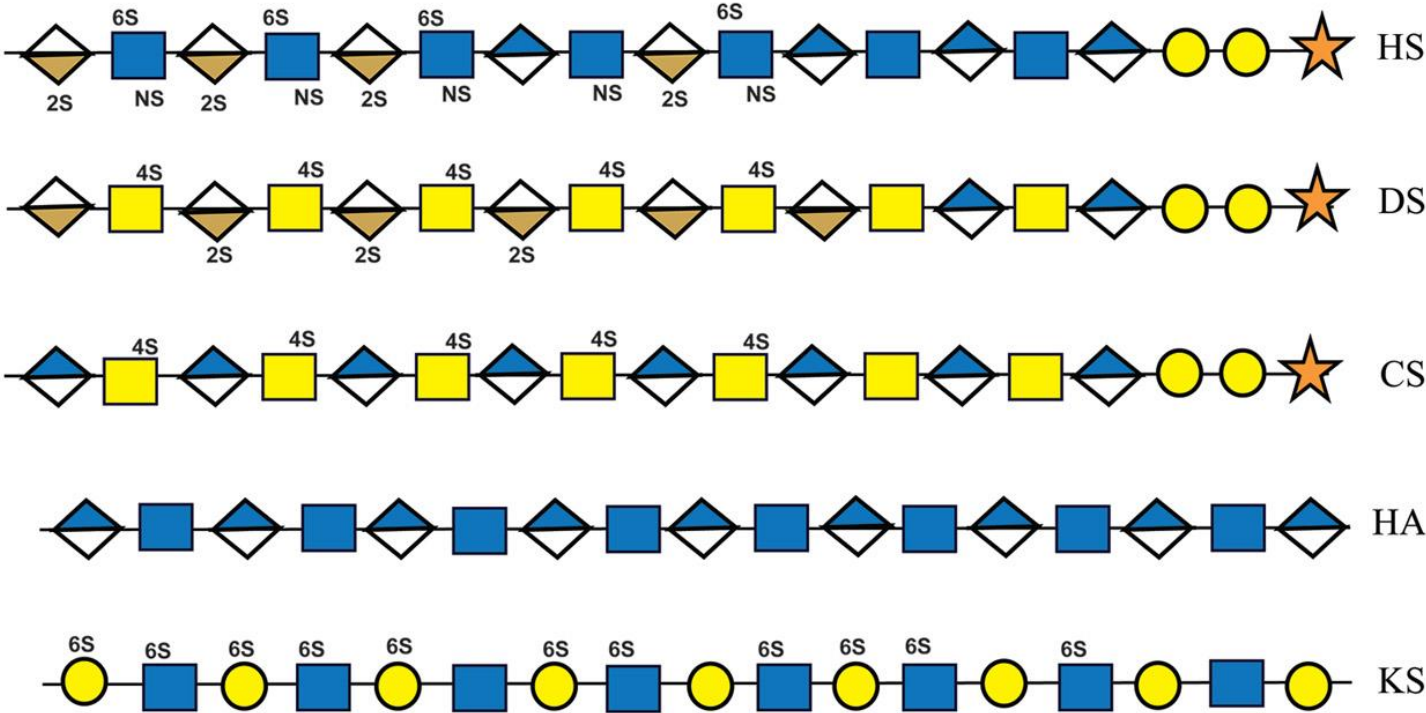
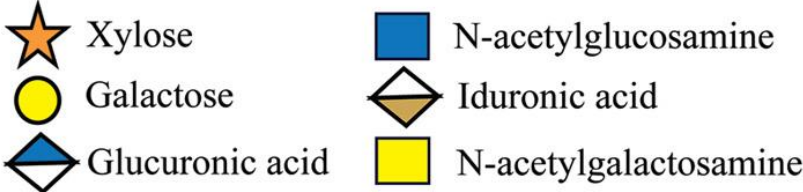

J Histochem Cytochem. 60:885-97, 2012

Proteoglycans

GAG chains

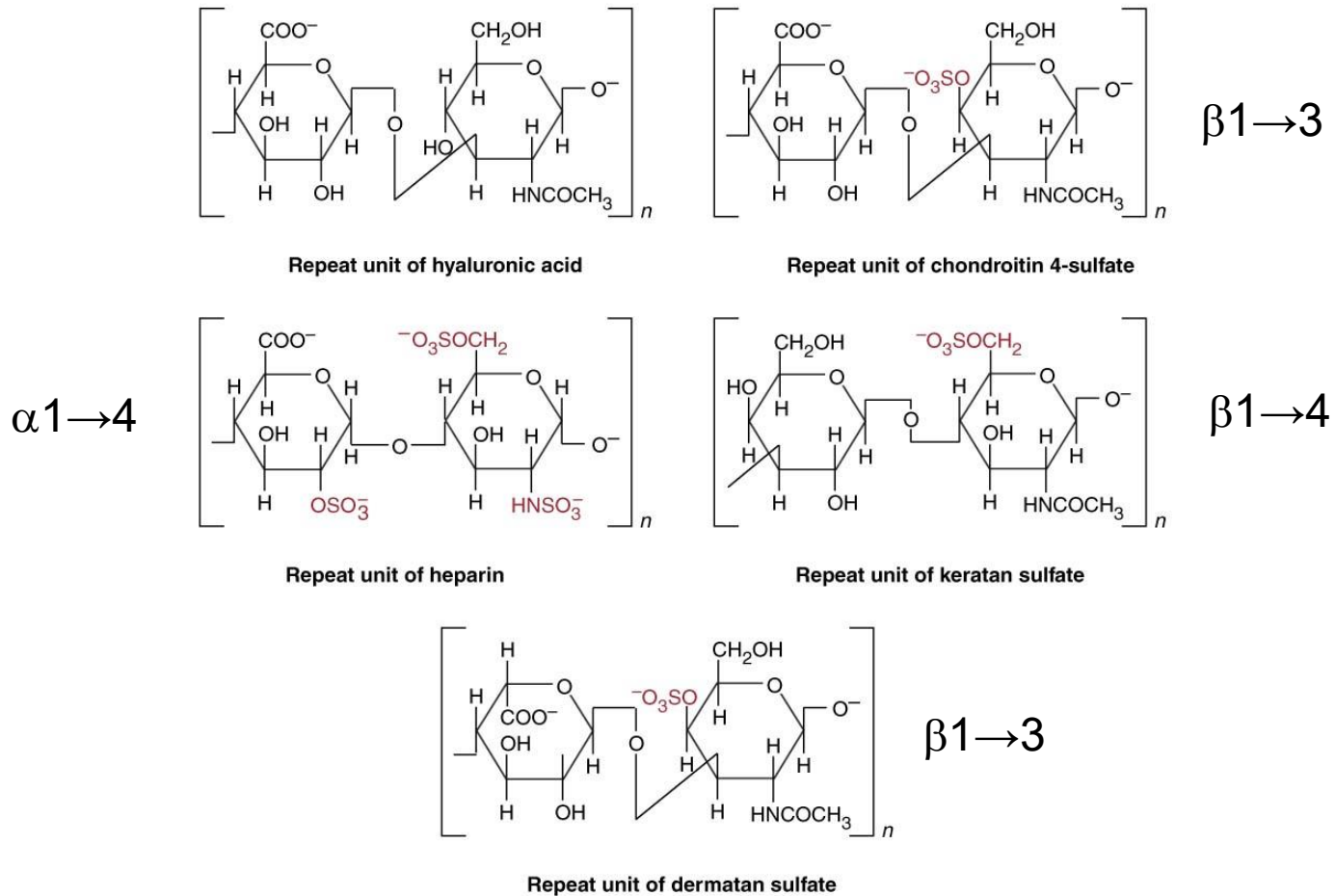
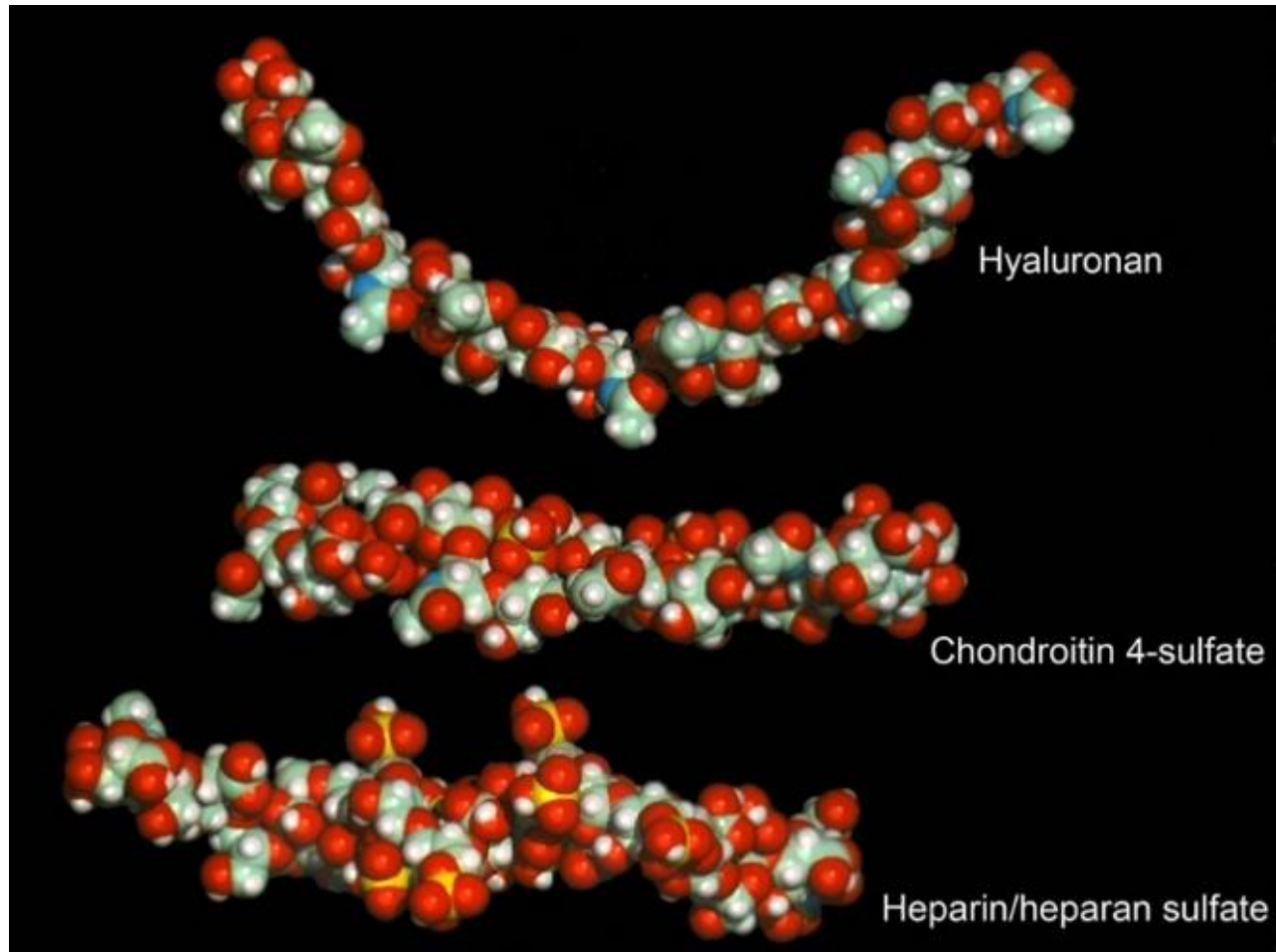

Figure 16.12. Major repeat units of glycosaminoglycan chains.

Textbook of Biochemistry With Clinical Correlations, Sixth Edition, Edited by Thomas M. Devlin. Copyright © 2006 John Wiley & Sons, Inc.

Proteoglycans

GAG chains



M. Yanagishita, personal comm.

Proteoglycans

Chondroitin Sulfate (CS)

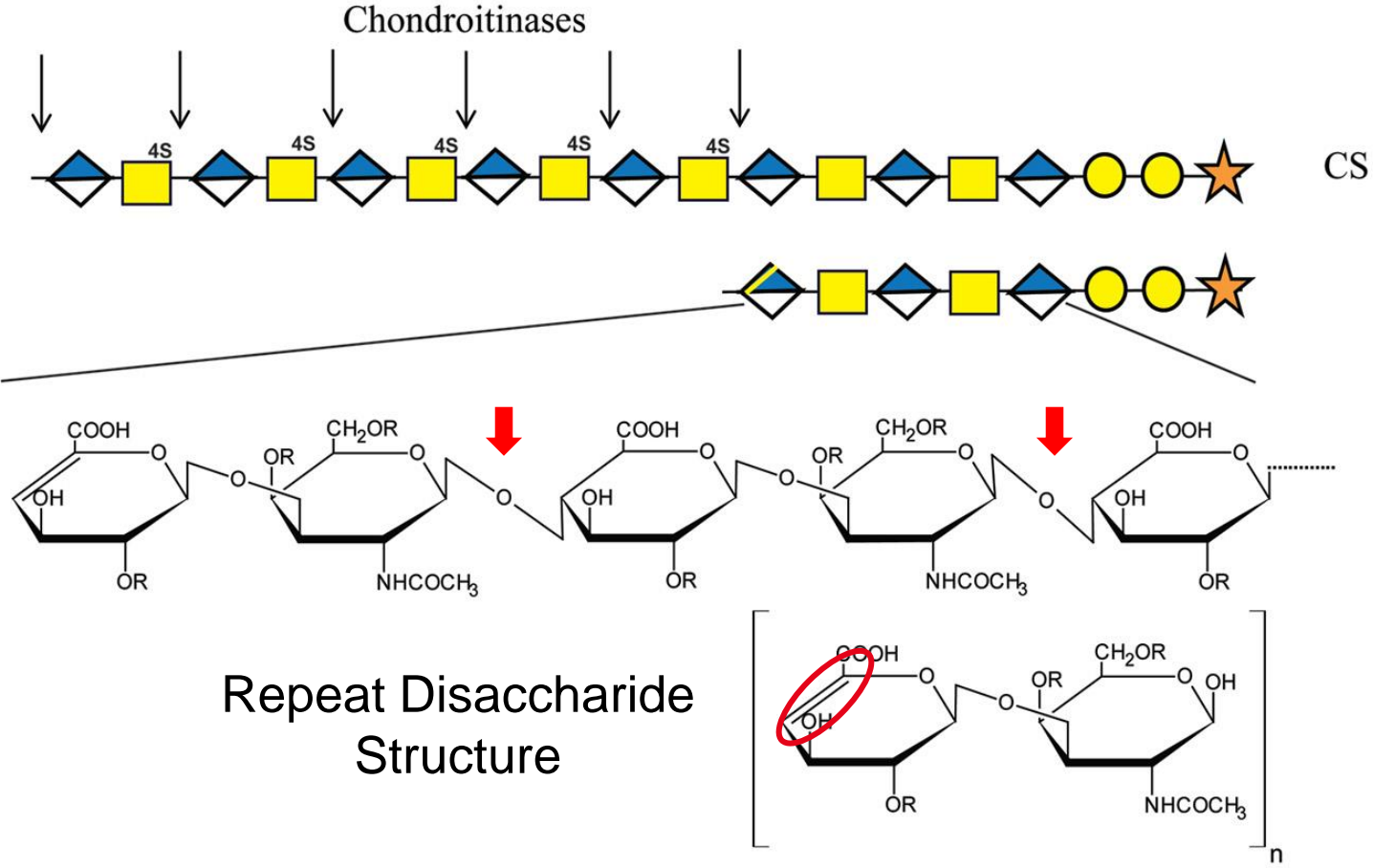

J Histochem Cytochem. 60:885-97, 2012

Proteoglycans

Heparan Sulfate (HS)

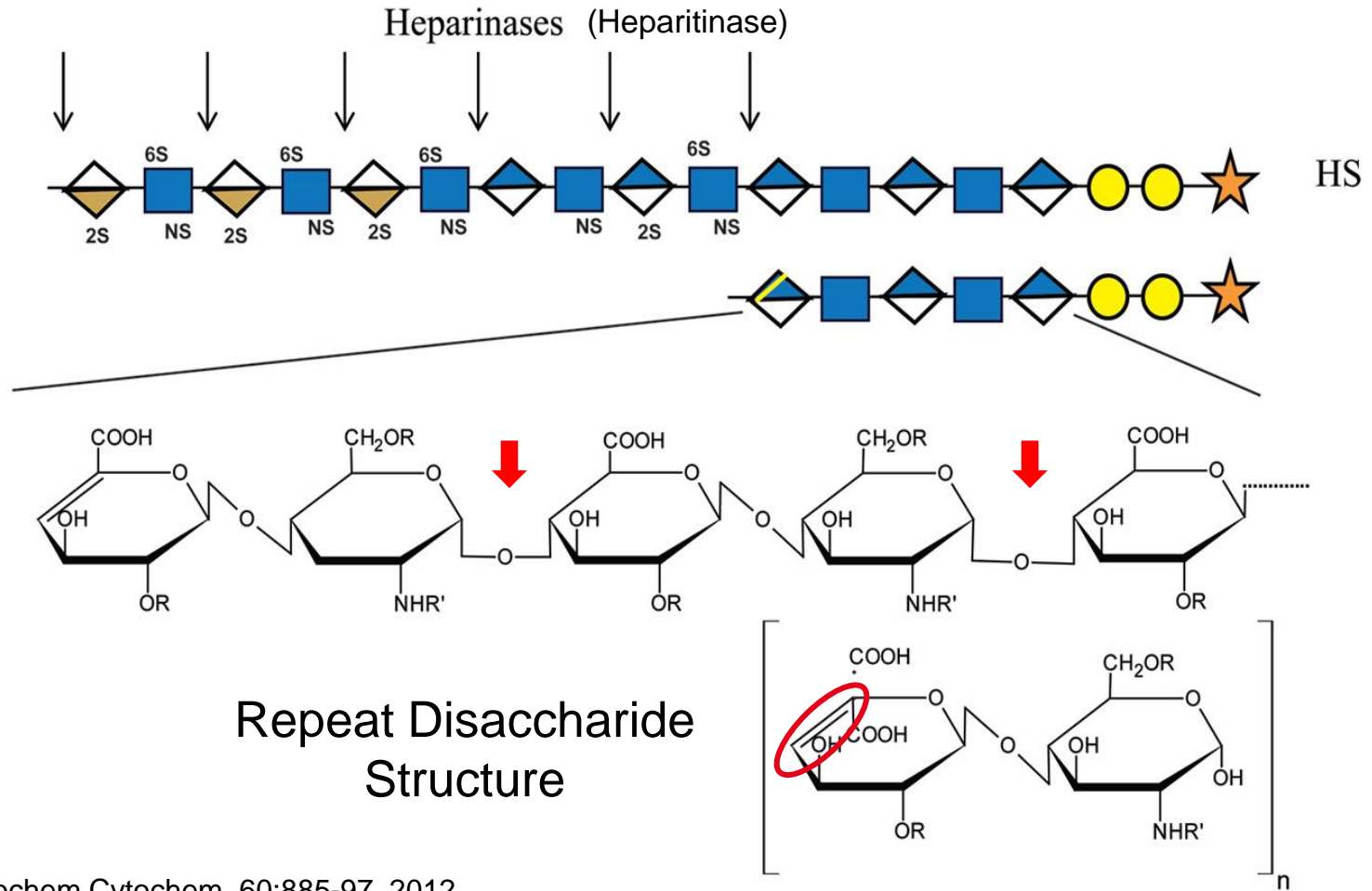

J Histochem Cytochem. 60:885-97, 2012

Hyaluronan (HA):

Only GAG not synthesized on a core protein

β 1,4 glucuronic acid β 1,3 N-acetylgalactosamine β 1,4

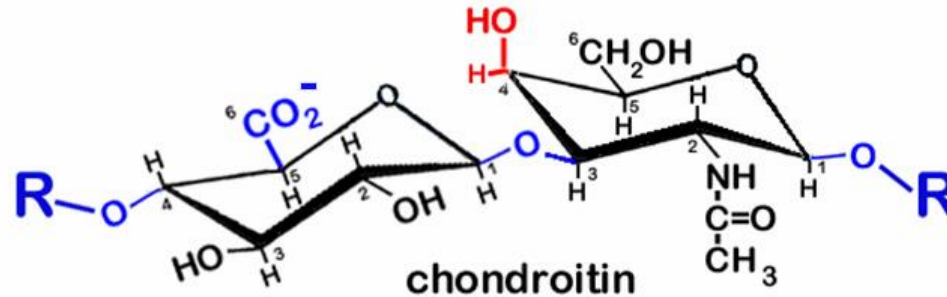

β 1,4 glucuronic acid β 1,3 N-acetylglucosamine β 1,4

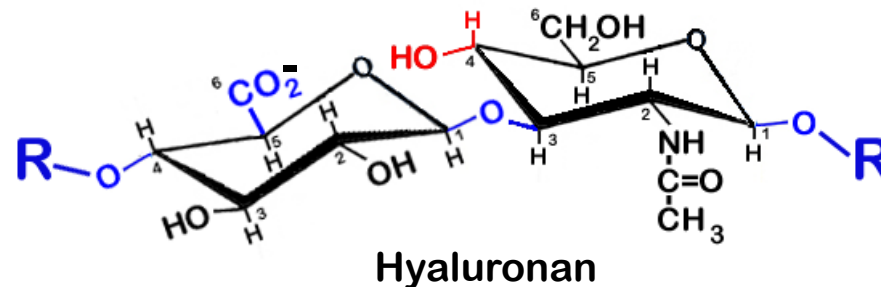

Hyaluronan Consists of Repeating Disaccharides Composed of *N*-Acetylglucosamine and Glucuronic Acid

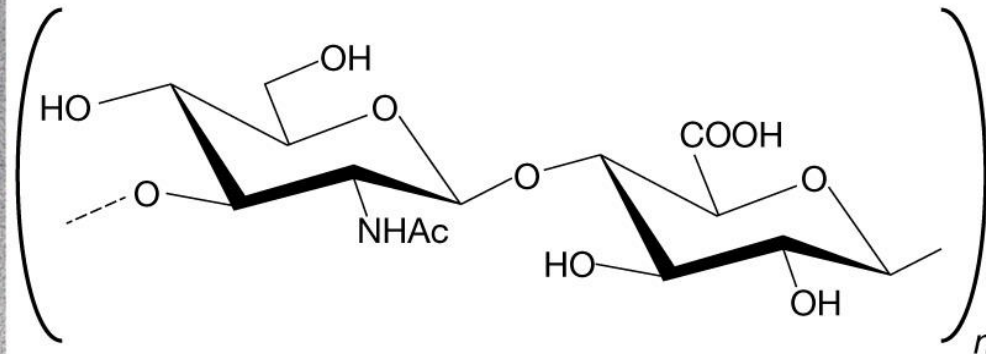
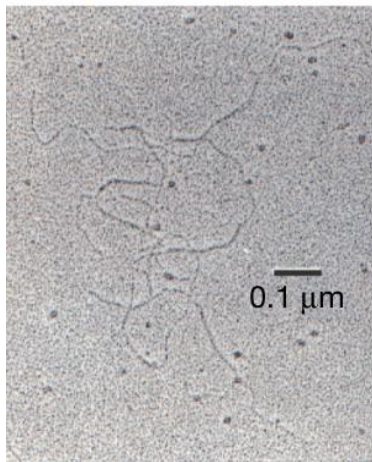
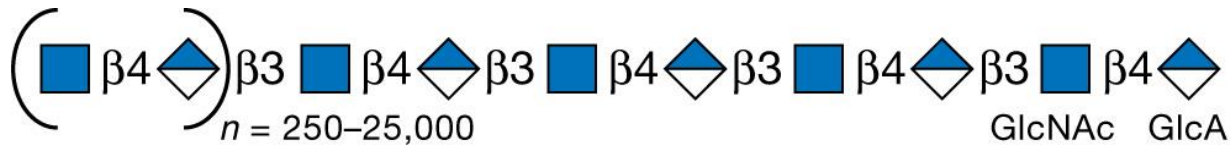

Chapter 16, Figure 1. *Essentials of Glycobiology*, Third Edition

Symbol Nomenclature for Glycans (SNFG)

©2017 The Consortium of Glycobiology Editors, La Jolla, California



Buy the Book

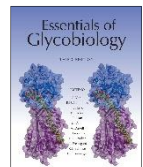

Hyaluronan Biosynthesis by Hyaluronan Synthase

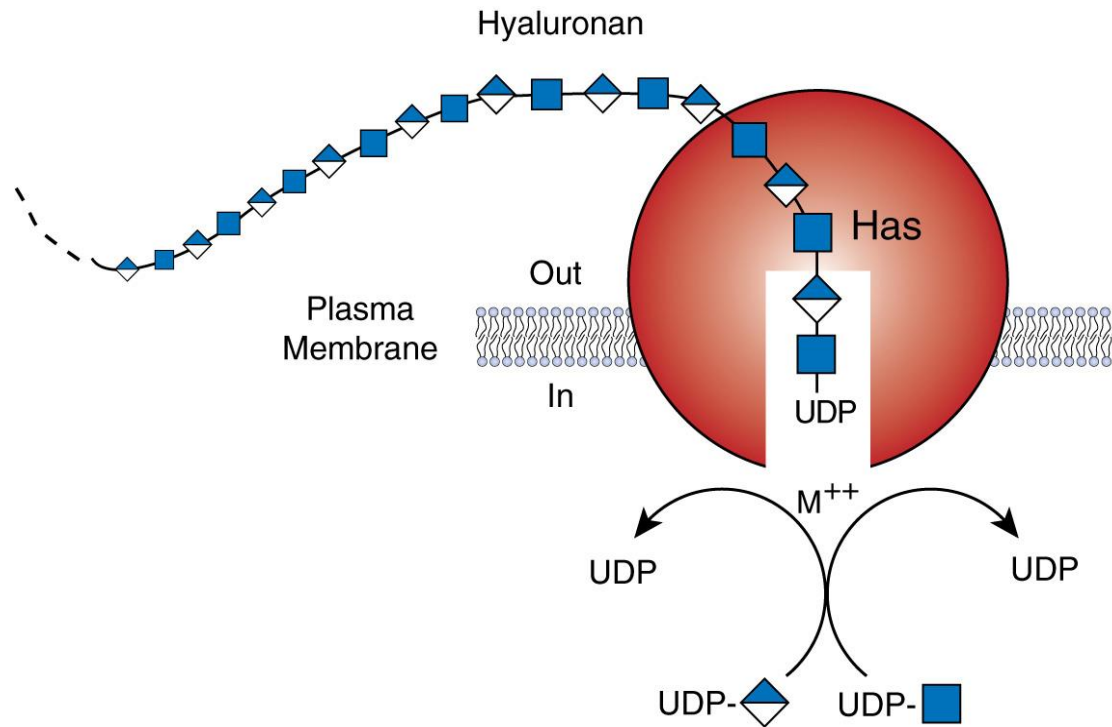

Chapter 16, Figure 2. *Essentials of Glycobiology*, Third Edition

Symbol Nomenclature for Glycans (SNFG)

©2017 The Consortium of Glycobiology Editors, La Jolla, California



Buy the Book

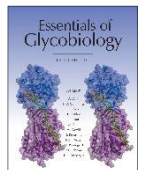

HA is the only GAG synthesized at the plasma membrane and directly extruded into the extracellular space

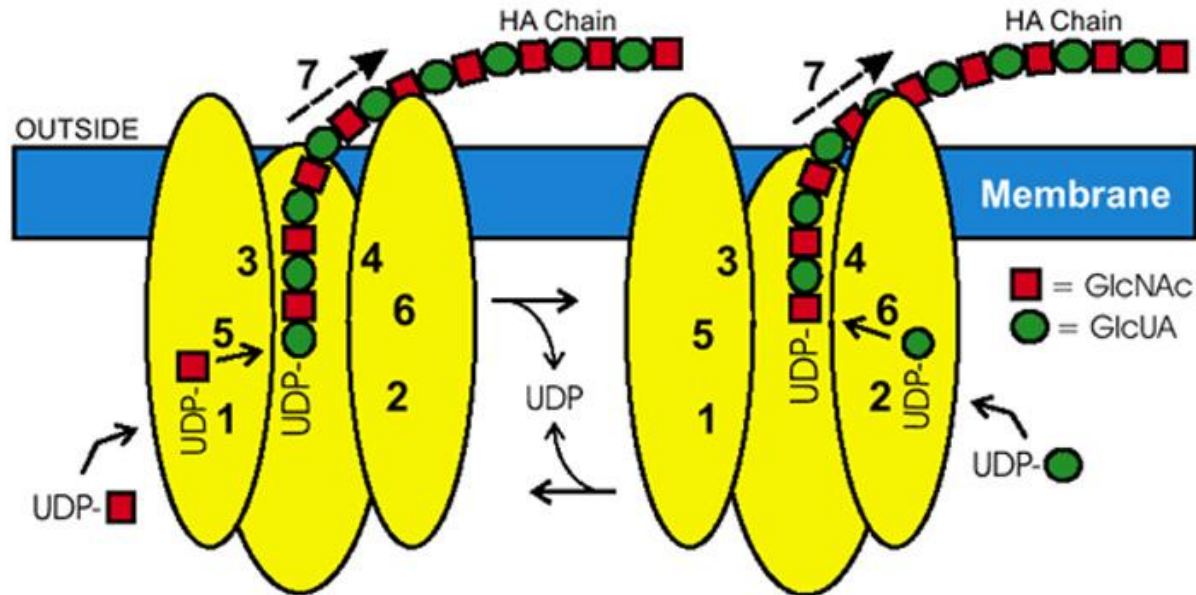

Multiple Functions of Class I HA Synthases

Addition of GlcNAc to the Growing HA-GlcUA-UDP Chain (left)

1. UDP-GlcNAc Acceptor Binding
3. HA-GlcUA-UDP Donor Binding
5. HA-GlcUA-UDP: UDP-GlcNAc, beta-1,3(HA-GlcUA) transferase
7. HA translocation through the membrane

Addition of GlcUA to the Growing HA-GlcNAc-UDP Chain (right)

2. UDP-GlcUA Acceptor Binding
4. HA-GlcNAc-UDP Donor Binding
6. HA-GlcNAc-UDP: UDP-GlcUA, beta-1,4(HA-GlcNAc) transferase
7. HA translocation through the membrane

Int J Cell Biol (2015) <http://dx.doi.org/10.1155/2015/367579>

Modular Organization of the Link Module Superfamily of Hyaluronan-Binding Proteins (Hyaladherins)

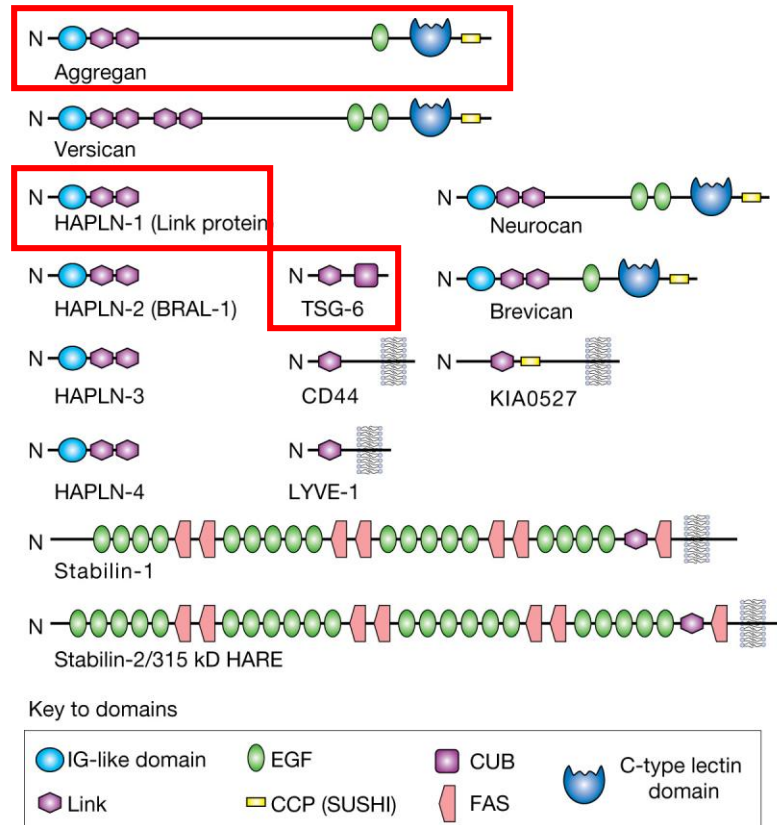

Chapter 16, Figure 3. *Essentials of Glycobiology*, Third Edition

©2017 The Consortium of Glycobiology Editors, La Jolla, California

The Large Cartilage Chondroitin Sulfate Proteoglycan (Aggrecan) Forms an Aggregate

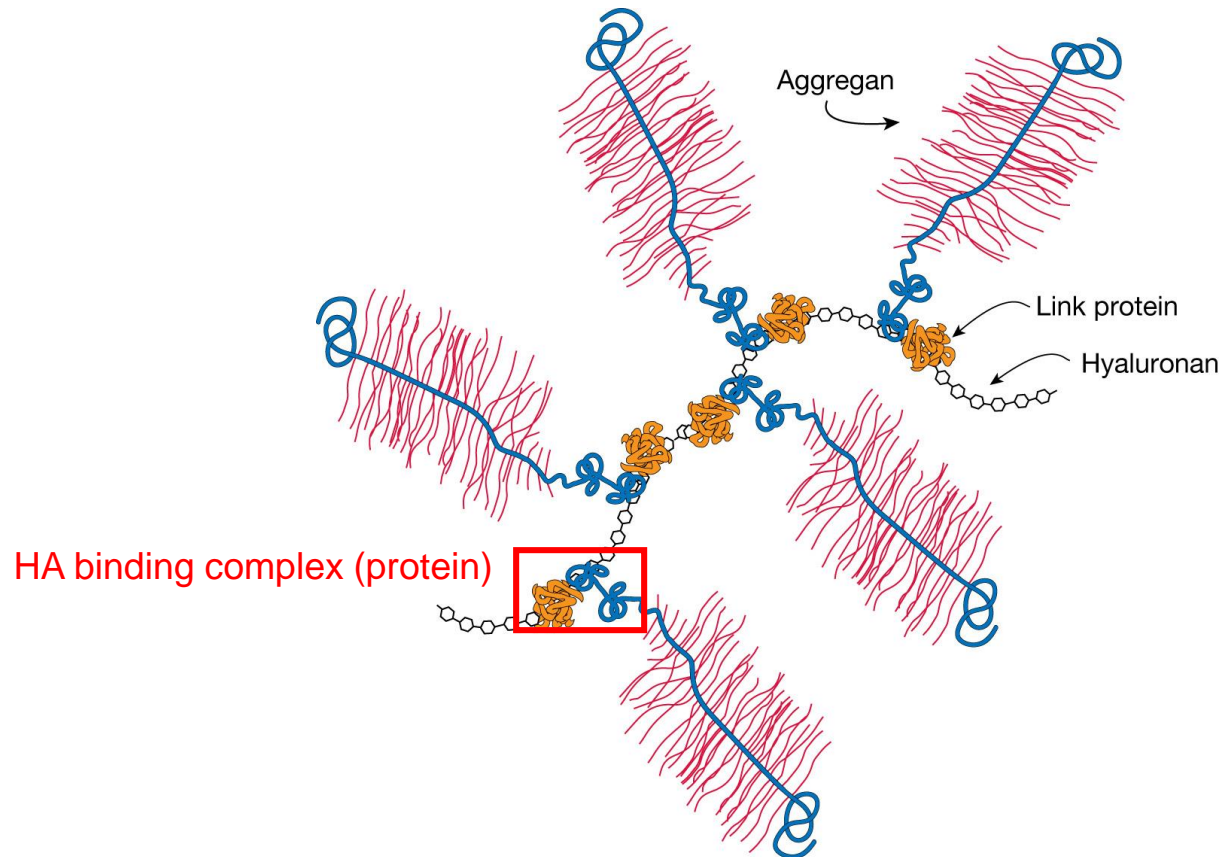

Chapter 16, Figure 4. *Essentials of Glycobiology*, Third Edition

©2017 The Consortium of Glycobiology Editors, La Jolla, California

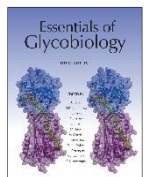

Structure of the Tumor Necrosis Factor Stimulated Gene-6 Protein (TSG-6) Link Module

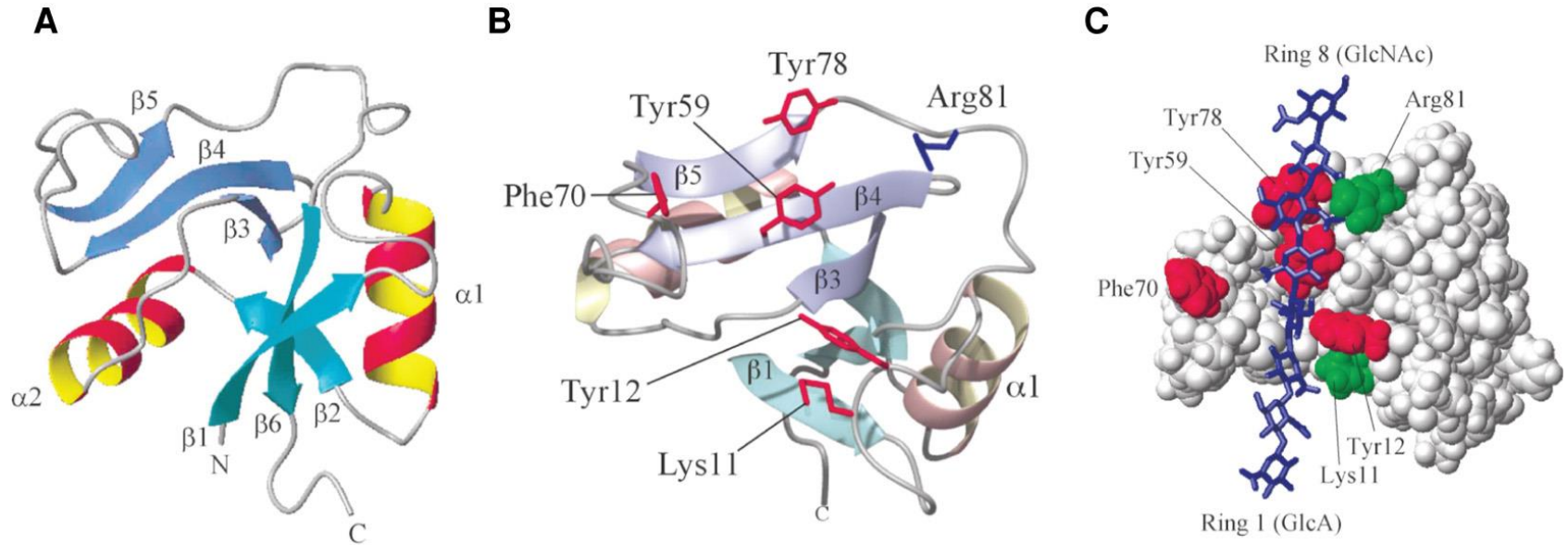

Chapter 16, Figure 5. *Essentials of Glycobiology*, Third Edition

©2017 The Consortium of Glycobiology Editors, La Jolla, California



Buy the Book

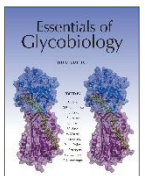

Covalent Transfer of Heavy Chain protein to HA in the Extracellular Matrix (ECM)

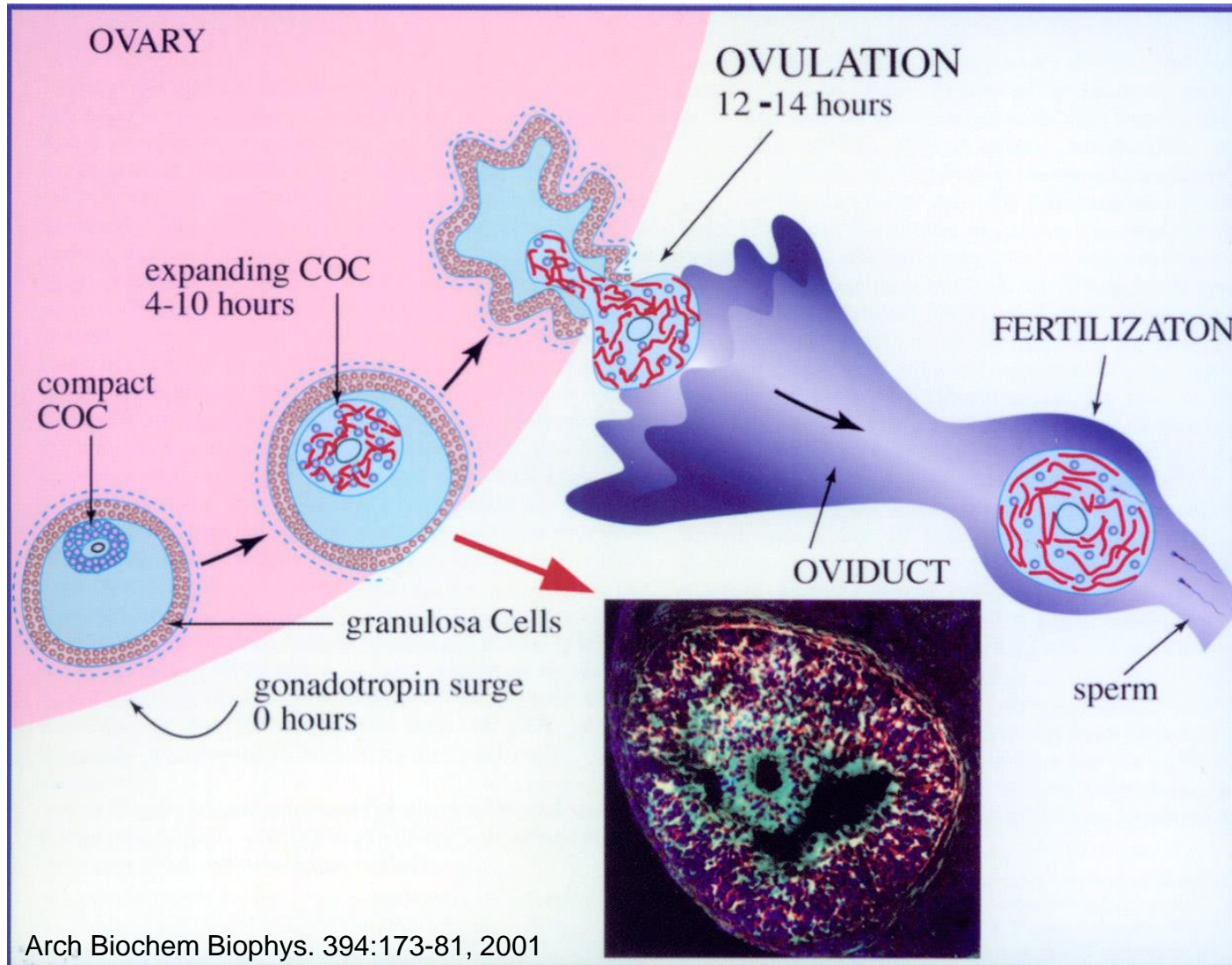

Covalent Transfer of Heavy Chain protein to HA in the Extracellular Matrix (ECM)

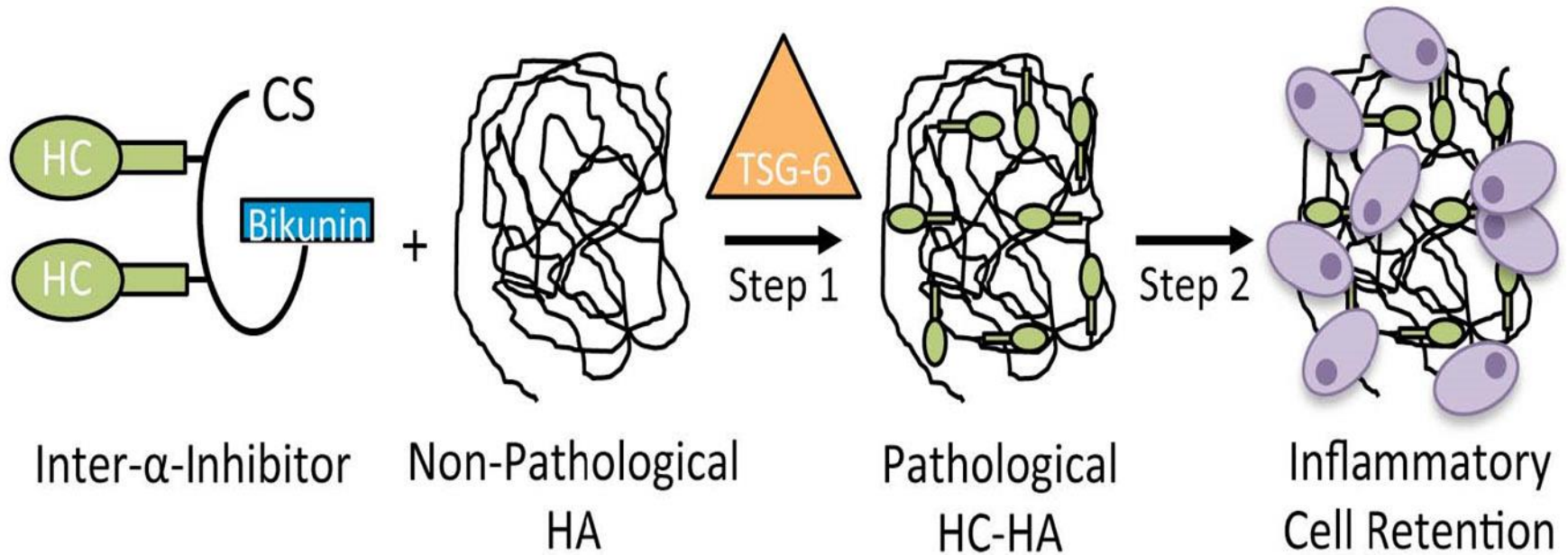

<http://pegnac.sdsc.edu/cleveland-clinic/files/PEGNAC-DAKO-Inter-alpha-Inhibitor-Antibody-1-14-16.pdf>

Heavy Chain – HA Staining of Inflamed Colon

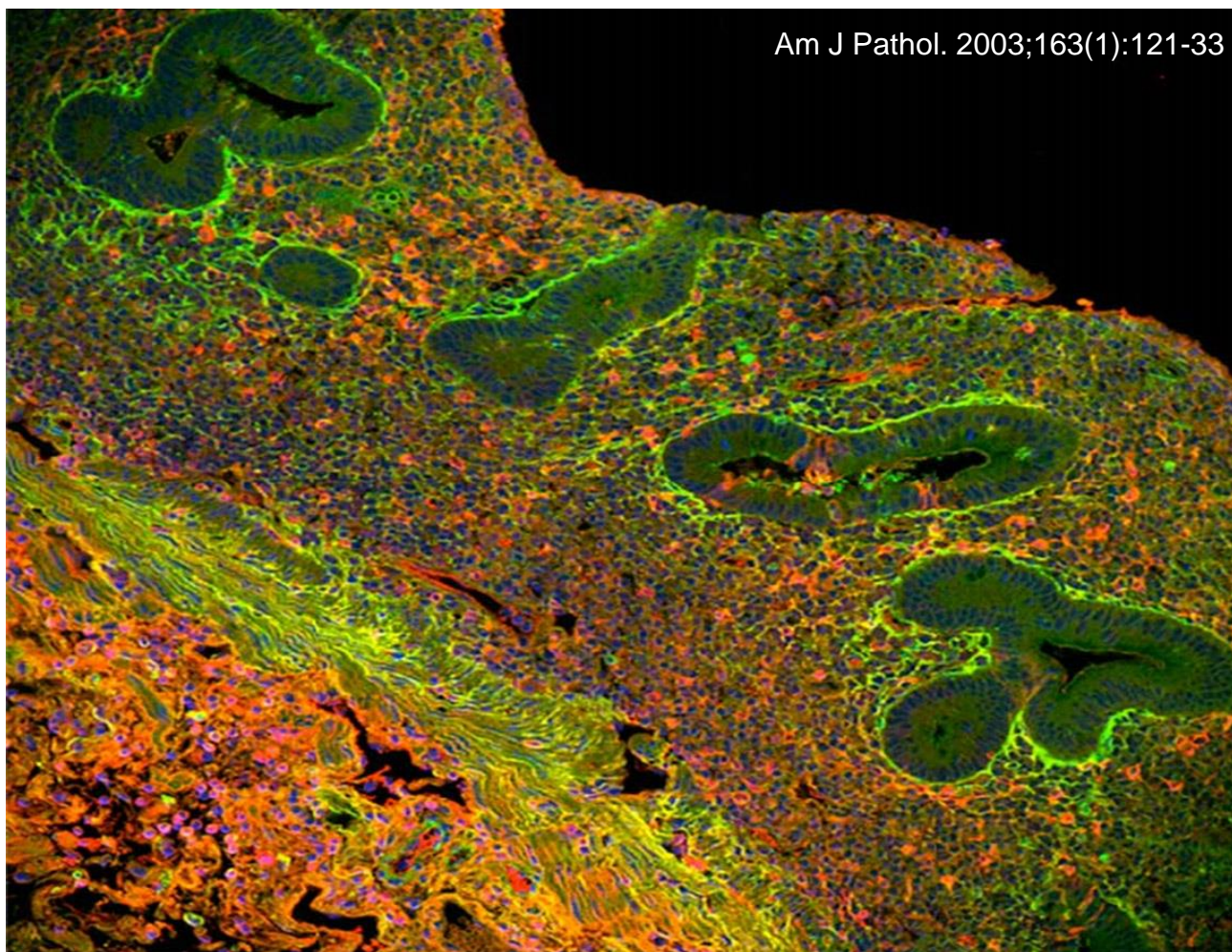

Human paraffin section stained with HABP (green),
Dako Icl antibody (red) & DAPI (blue).

Proteoglycans & Sulfated GAGs

High fixed negative charge density

β 1,4 glucuronic acid β 1,3 N-acetylgalactosamine β 1,4

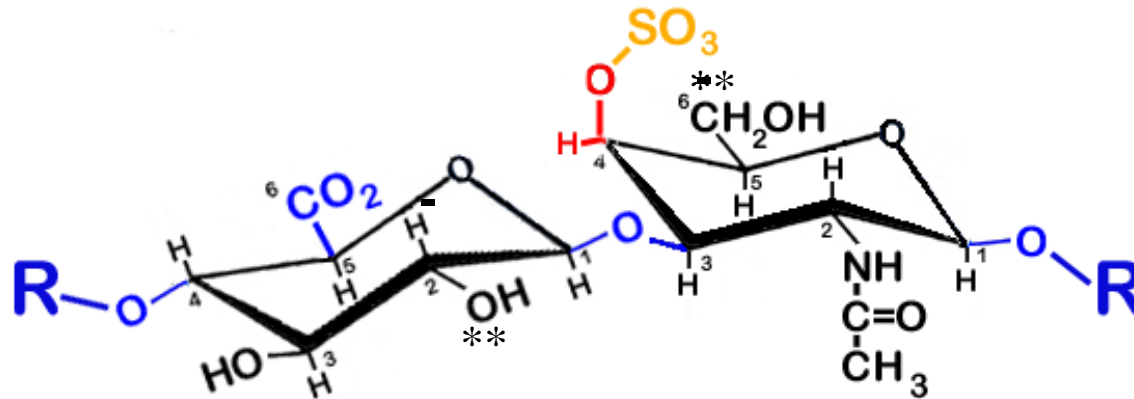

chondroitin-4-sulfate

Shown is sulfate group linked to 4-position of N-acetylgalactosamine
(**other sites for sulfation)

Proteoglycans

Intracellular GAG synthesis

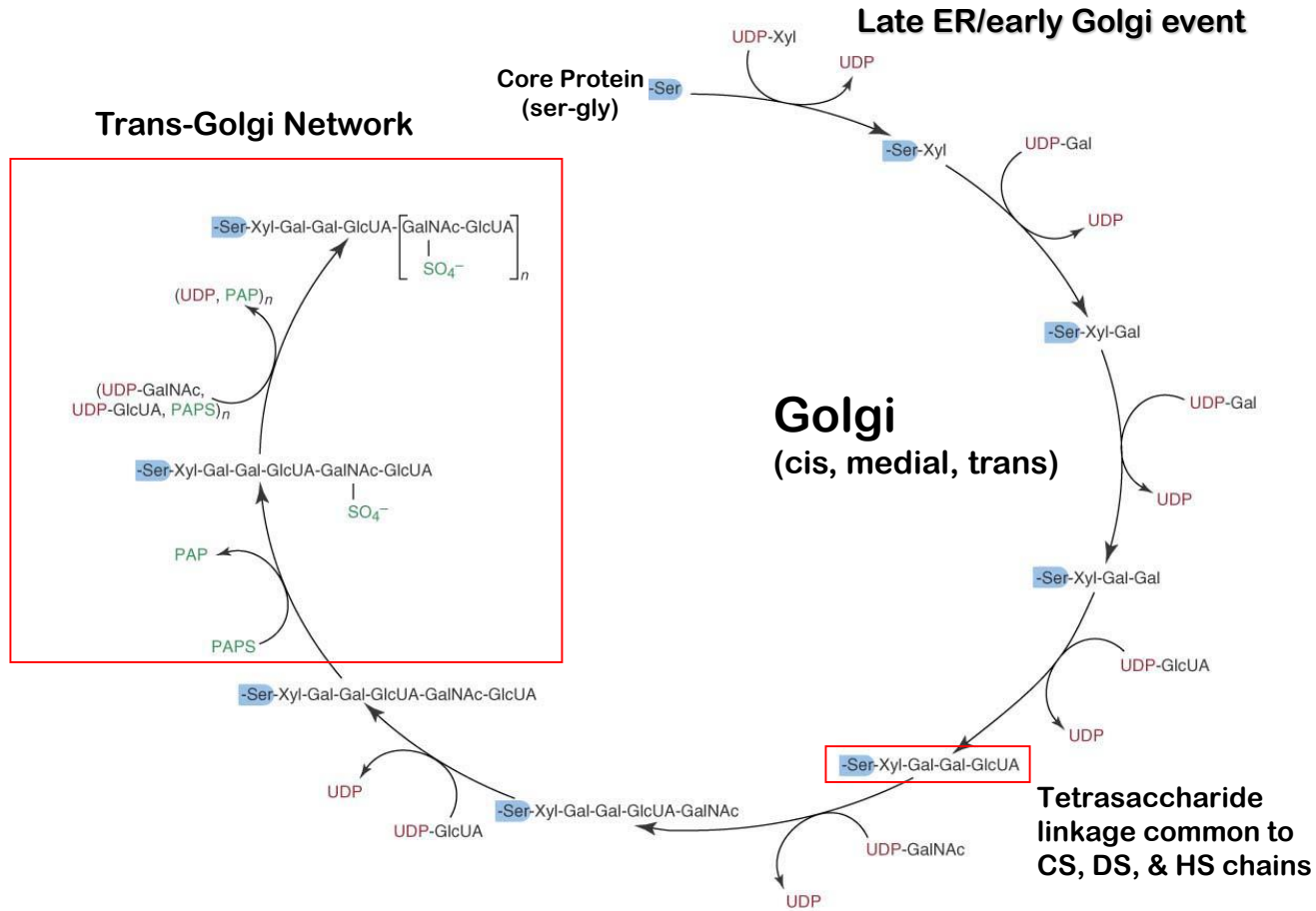

Figure 16.13. Synthesis of chondroitin sulfate proteoglycan.

Textbook of Biochemistry With Clinical Correlations, Sixth Edition, Edited by Thomas M. Devlin. Copyright © 2006 John Wiley & Sons, Inc.

Proteoglycans

Sulfation of GAG chains requires nucleotide-linked sulfate

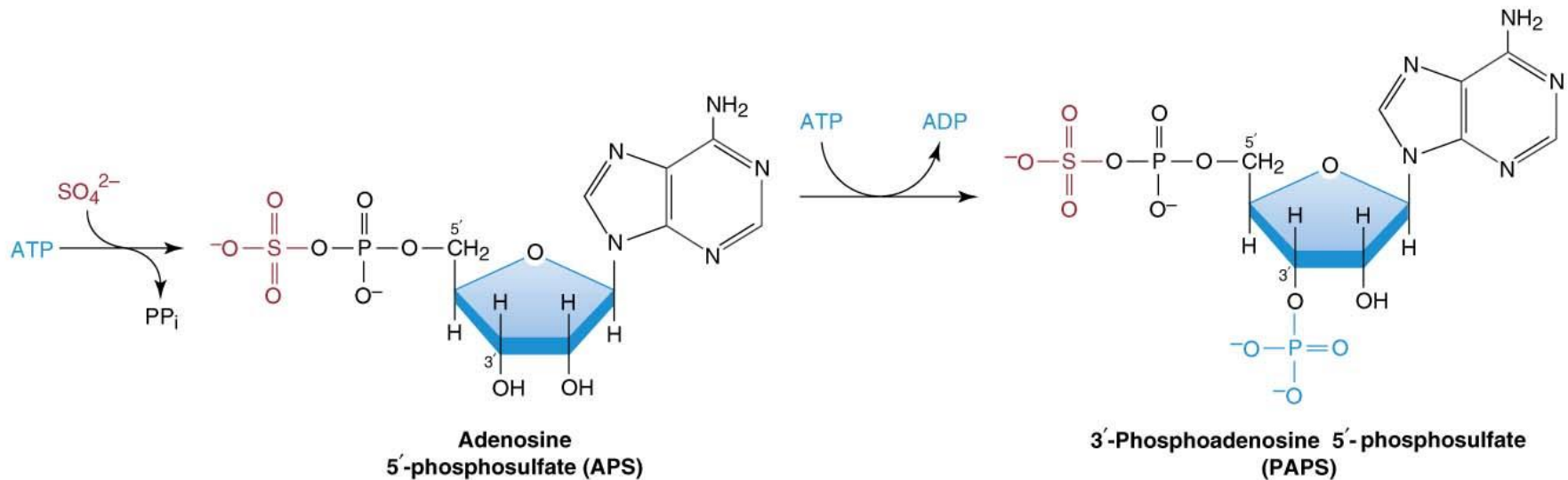
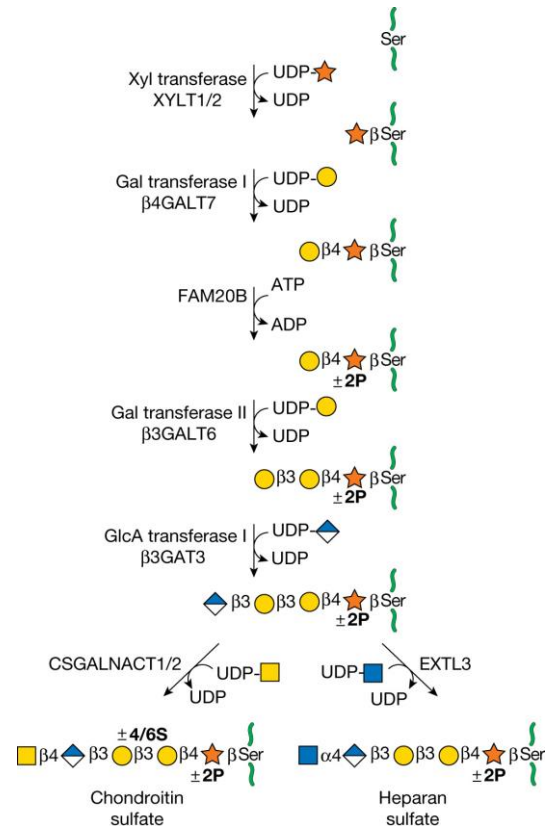

Figure 16.14. Biosynthesis of 3'-phosphoadenosine 5'-phosphosulfate (PAPS).

Textbook of Biochemistry With Clinical Correlations, Sixth Edition, Edited by Thomas M. Devlin. Copyright © 2006 John Wiley & Sons, Inc.

Biosynthesis of Chondroitin Sulfate and Heparan Sulfate



Chapter 17, Figure 4. *Essentials of Glycobiology*, Third Edition

Symbol Nomenclature for Glycans (SNFG)

©2017 The Consortium of Glycobiology Editors, La Jolla, California



Buy the Book

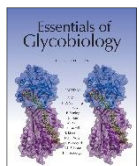

Proteoglycans

Linkage Oligosaccharides

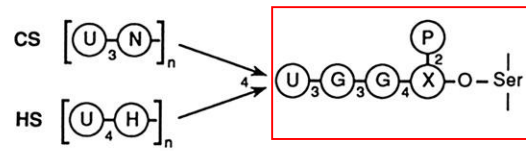

CS, DS, and HS

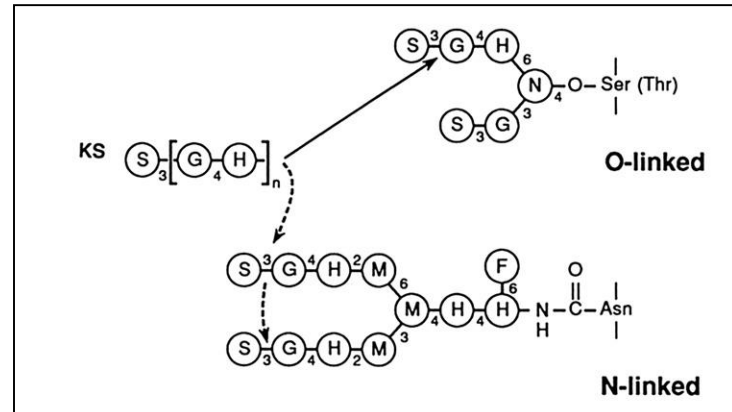

KS-II

KS

KS-I

- | | |
|---------------------|-----------------|
| (X) xylose | (N) galNAc |
| (G) galactose | (M) mannose |
| (U) glucuronic acid | (F) fucose |
| (H) glcNAc | (S) sialic acid |
| | (P) phosphate |

Keratan Sulfates Are a Sulfated Poly-*N*-Acetylactosamine

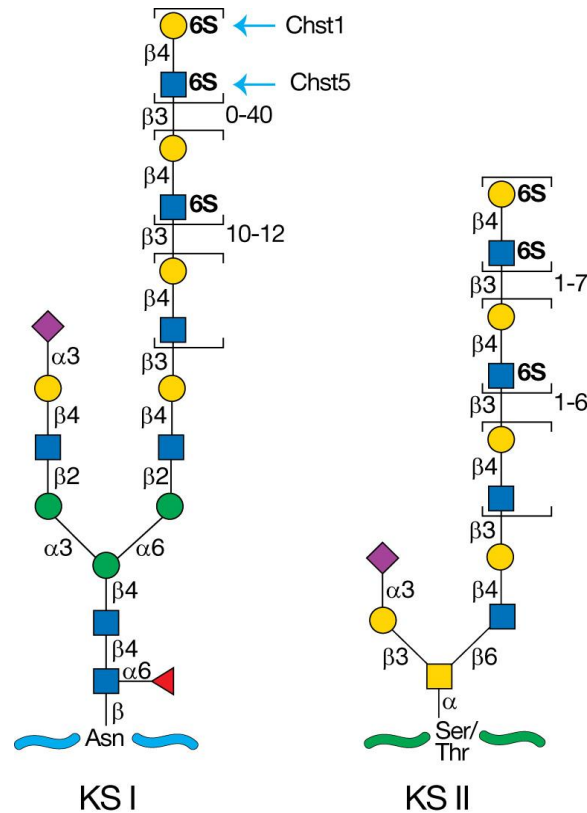

Chapter 17, Figure 3. *Essentials of Glycobiology*, Third Edition

Symbol Nomenclature for Glycans (SNFG)

©2017 The Consortium of Glycobiology Editors, La Jolla, California

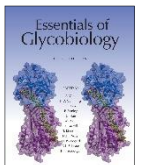

Protein Binding Domains of CS/DS and HS

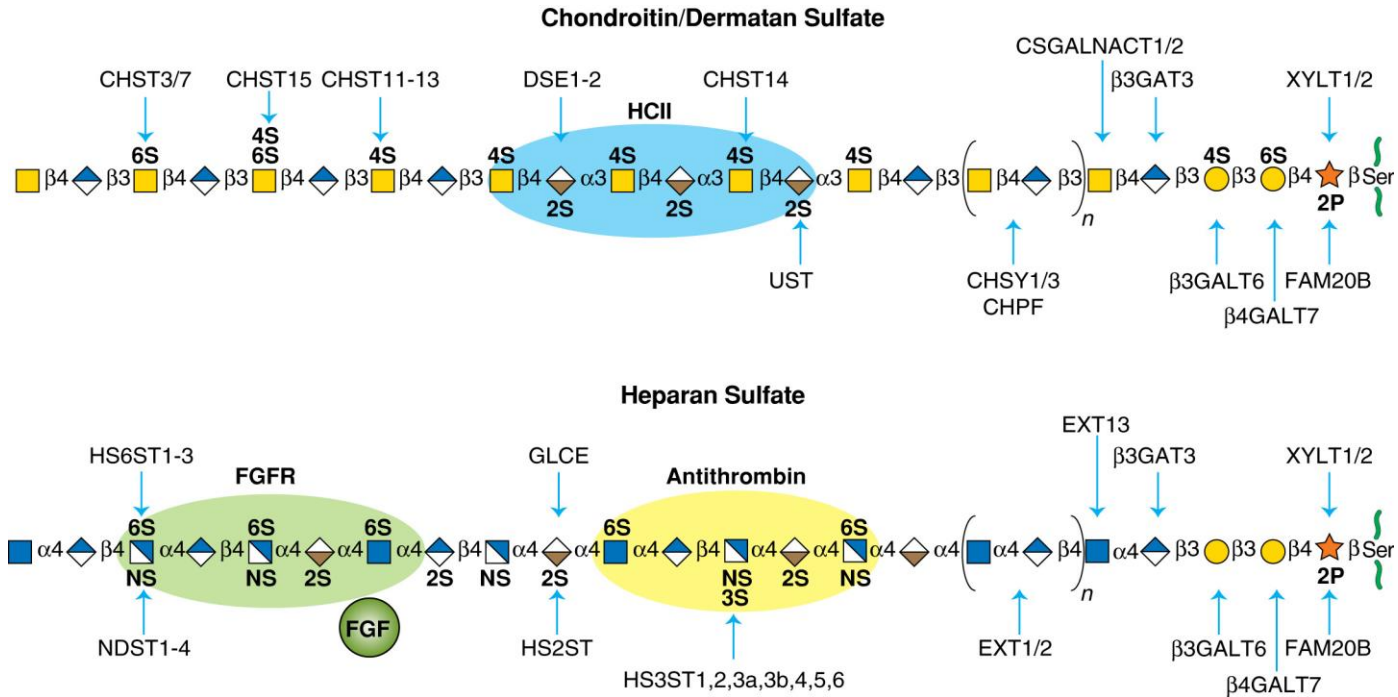

Heparin Cofactor II (HCII) is a human plasma serine proteinase inhibitor (serpin) that specifically inhibits thrombin

Chapter 17, Figure 5. *Essentials of Glycobiology*, Third Edition

Symbol Nomenclature for Glycans (SNFG)

©2017 The Consortium of Glycobiology Editors, La Jolla, California

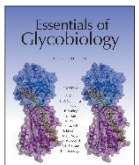

Proteoglycan Classes

1. Intracellular
2. Cell surface
3. Pericellular matrix & Basement Membrane
4. Extracellular matrix

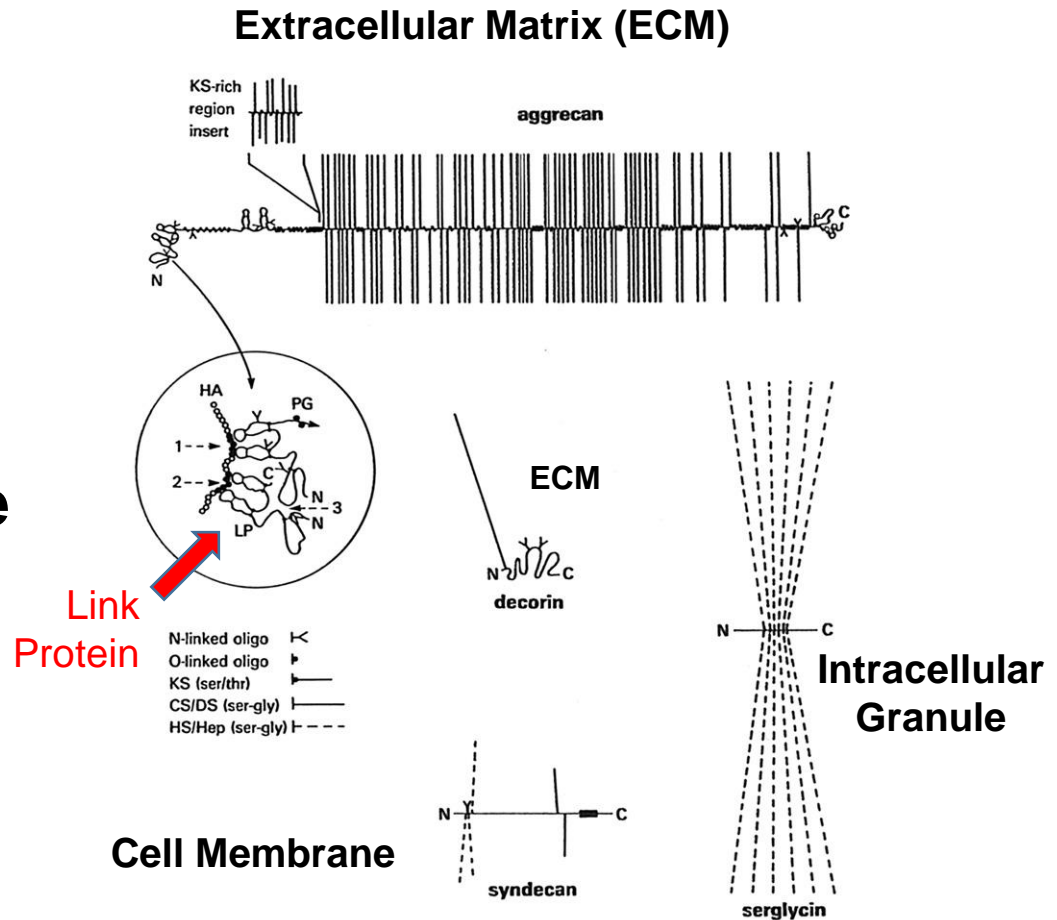

Intracellular Proteoglycans

Serglycin

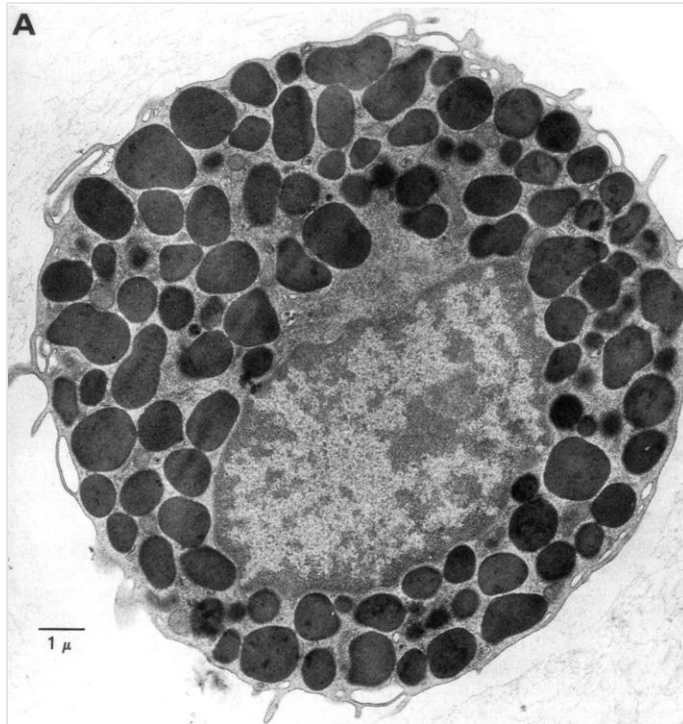

Mast cell

Frontiers Oncology 3, article 327, 2014
doi: 10.3389/fonc.2013.00327

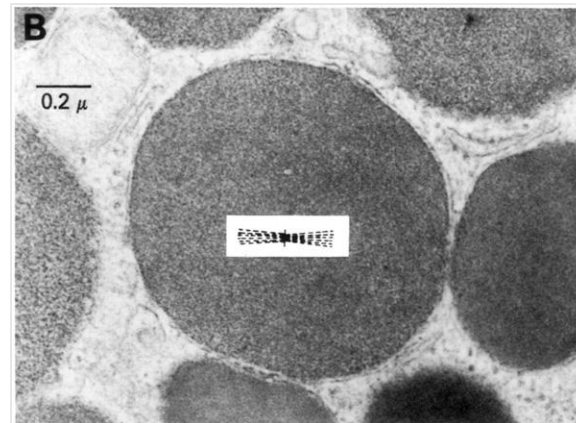

Intracellular secretory granule
(functions to package and inactivate
cationic secretory molecules such as
histamine and proteases)

Cell Surface Proteoglycans

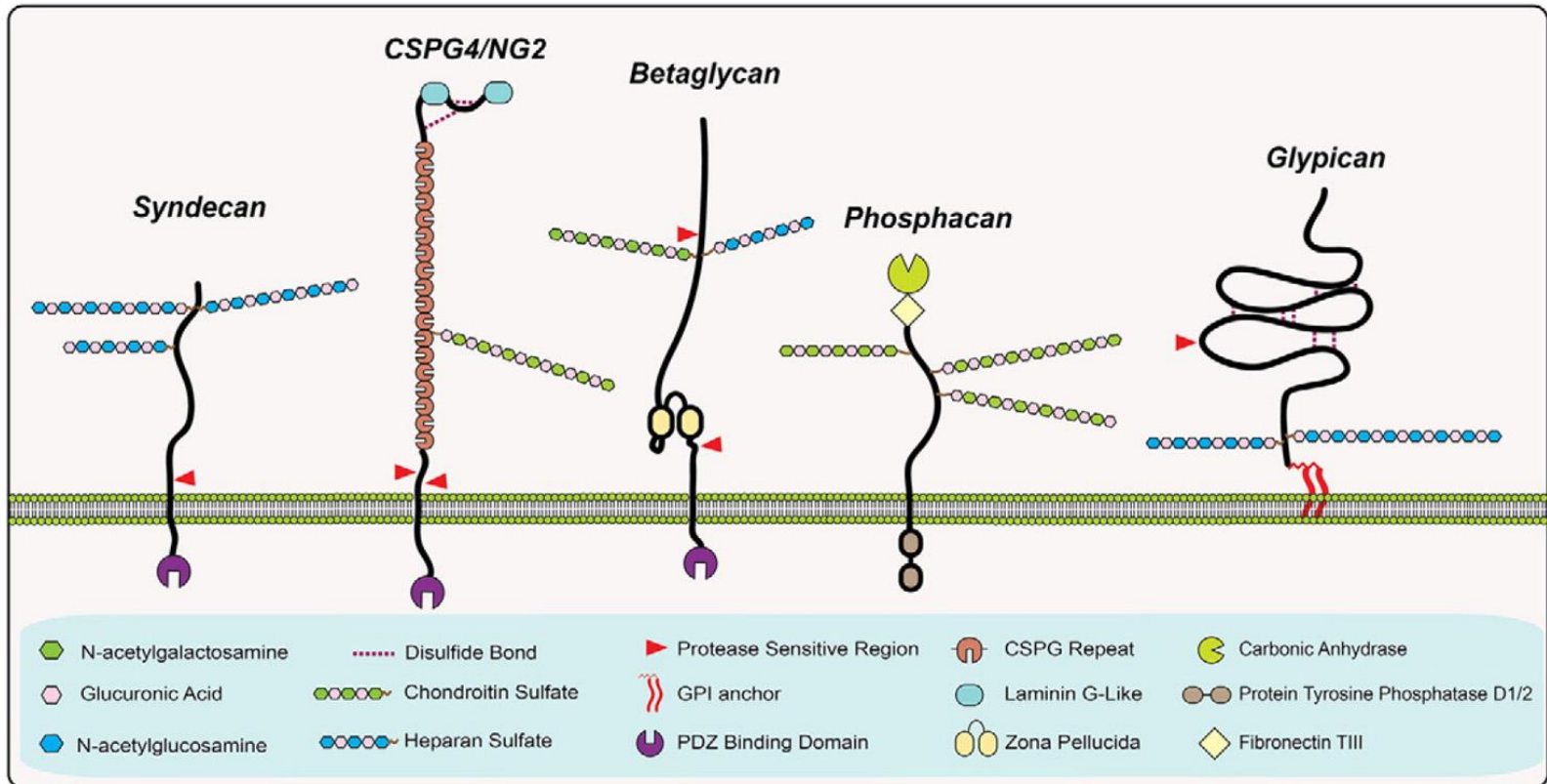

Matrix Biol. 42:11-55, 2015

Pericellular Matrix & Basement Membrane Proteoglycans

Matrix Biol. 42:11-55, 2015

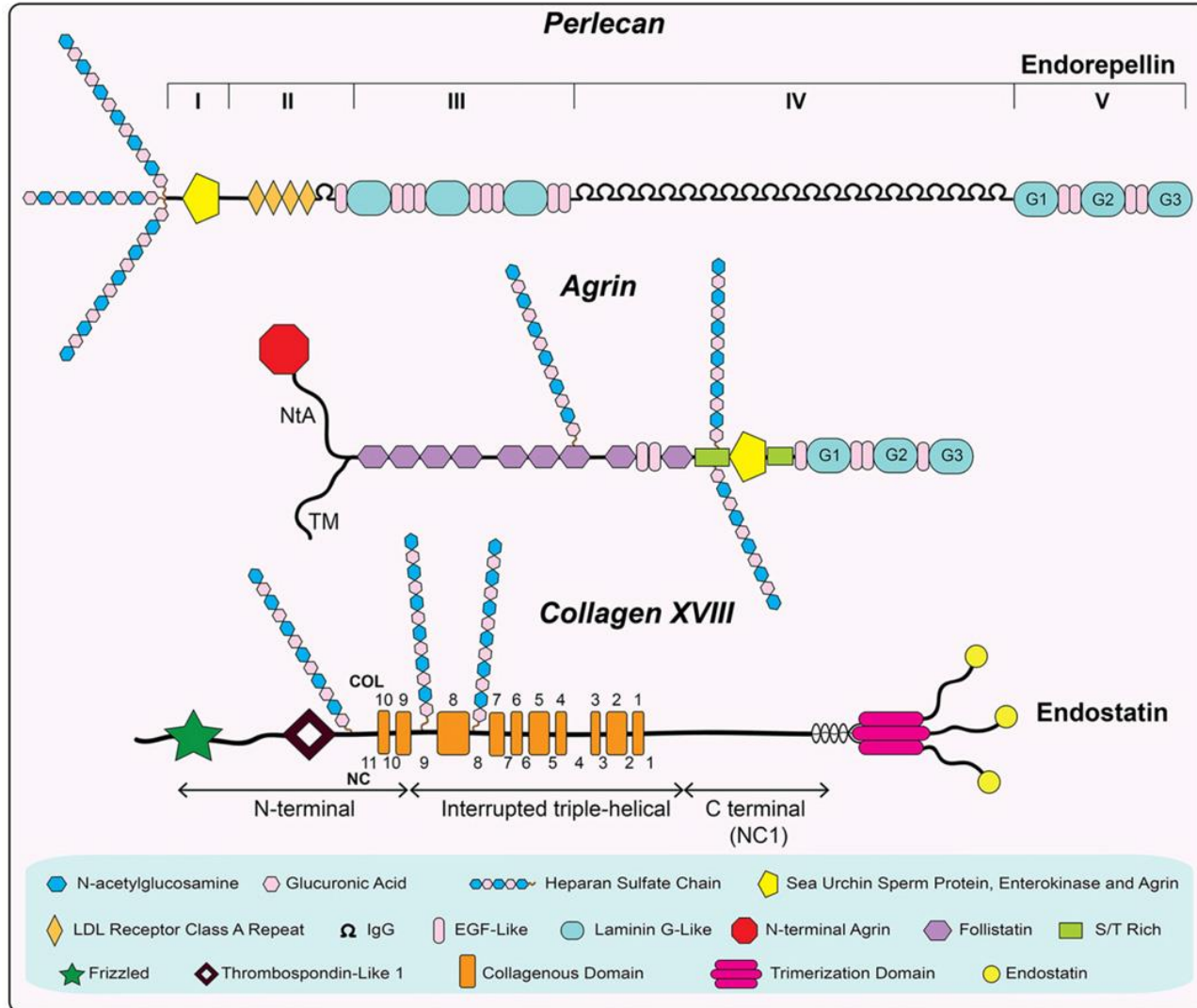

Extracellular Matrix Proteoglycans

Matrix Biol. 42:11-55, 2015

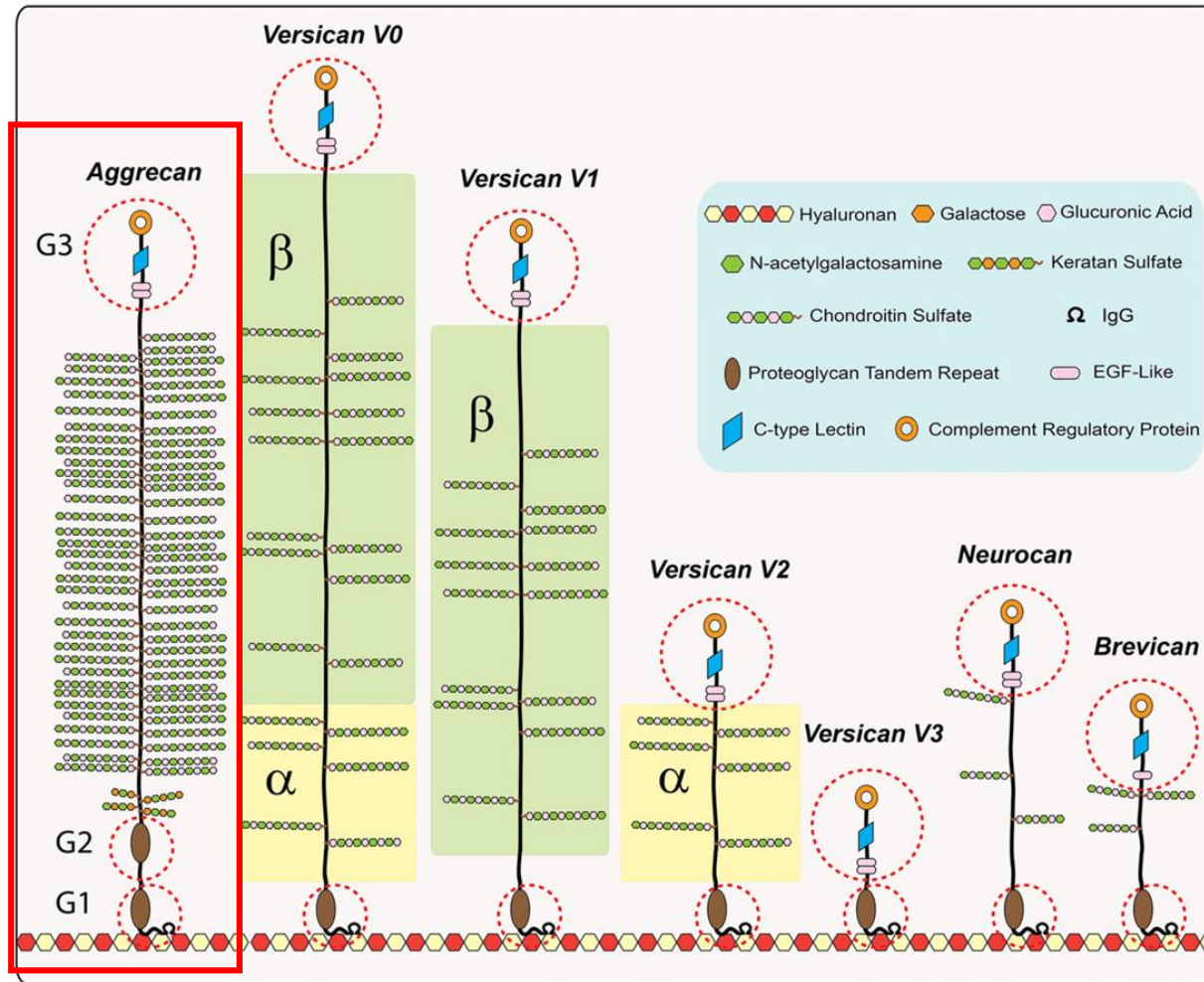

Link
Protein
Missing

Knee Joint Space

Synovial Fluid is a Viscoelastic Lubricant

Synovial fluid ~3 mg/ml hyaluronan

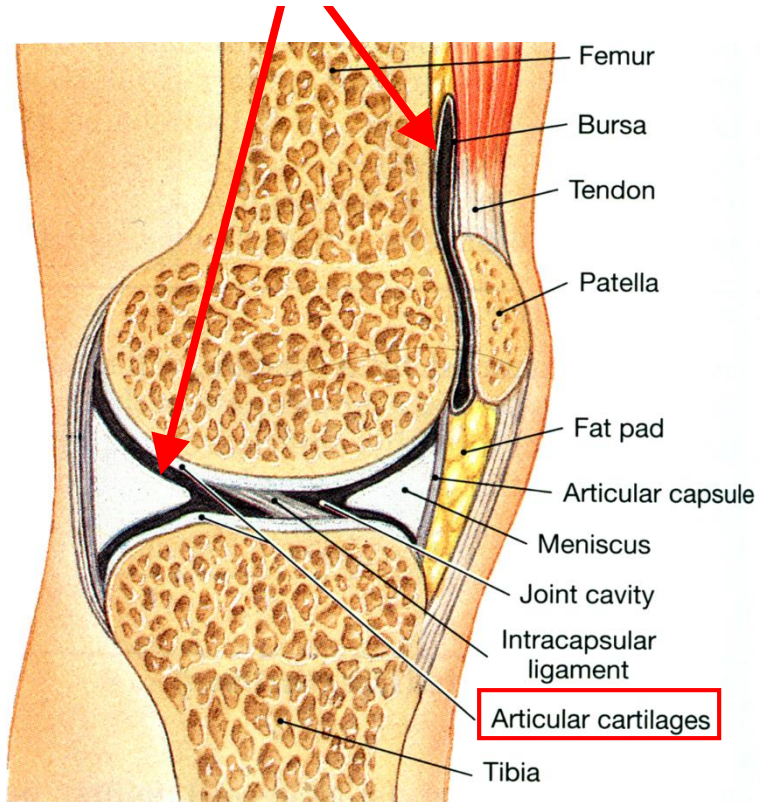

Knee Joint Articular Cartilage Osteochondral Processing and Histology

Femoral condyles

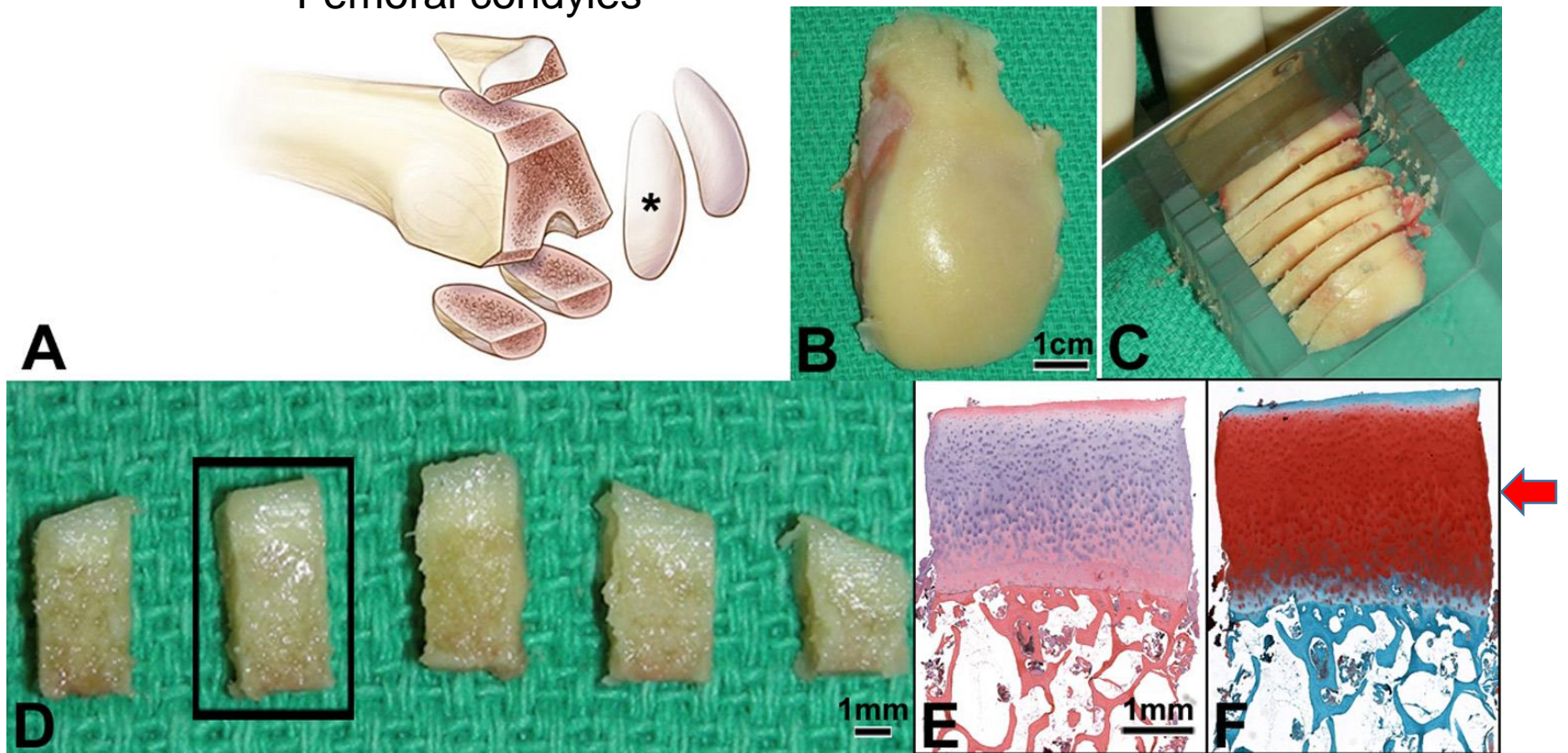

Acta Orthop. 89, 197-203, 2018

Safranin O stains sulfated GAGs

Extracellular Matrix Proteoglycans

Aggrecan

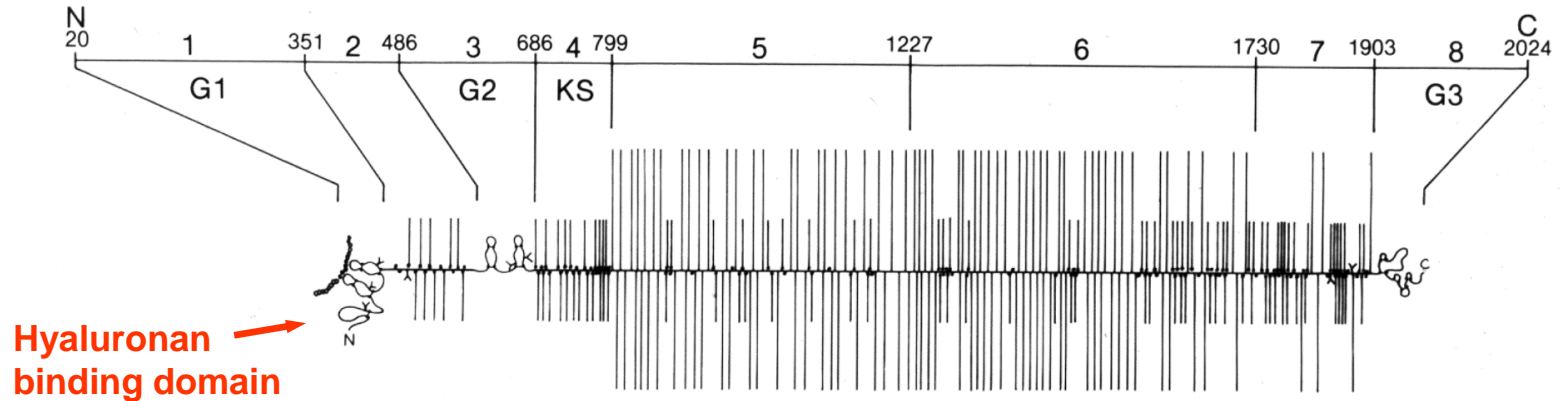

Electron Microscopy Rev.
1, 87-112, 1988

Aggrecan

Cartilage proteoglycan

~100 CS chains, ~100 KS chains (“bottle brush”)

$M_r \sim 2.5 \times 10^6$ Da

Length ~ 0.5 μm

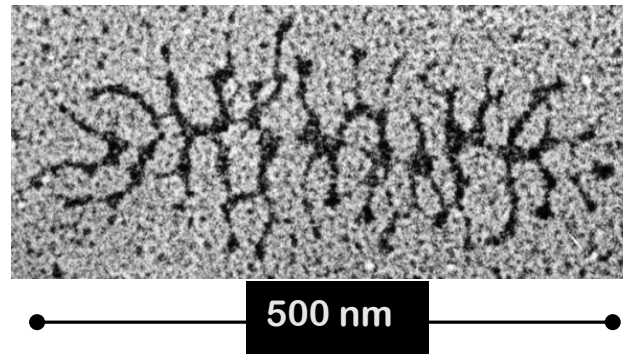

Aggregate: 1 hyaluronan + ~180 aggrecan monomers
Supramacromolecular complexes (5-8 μm length)

Electron Microscopy Rev.
1, 87-112, 1988

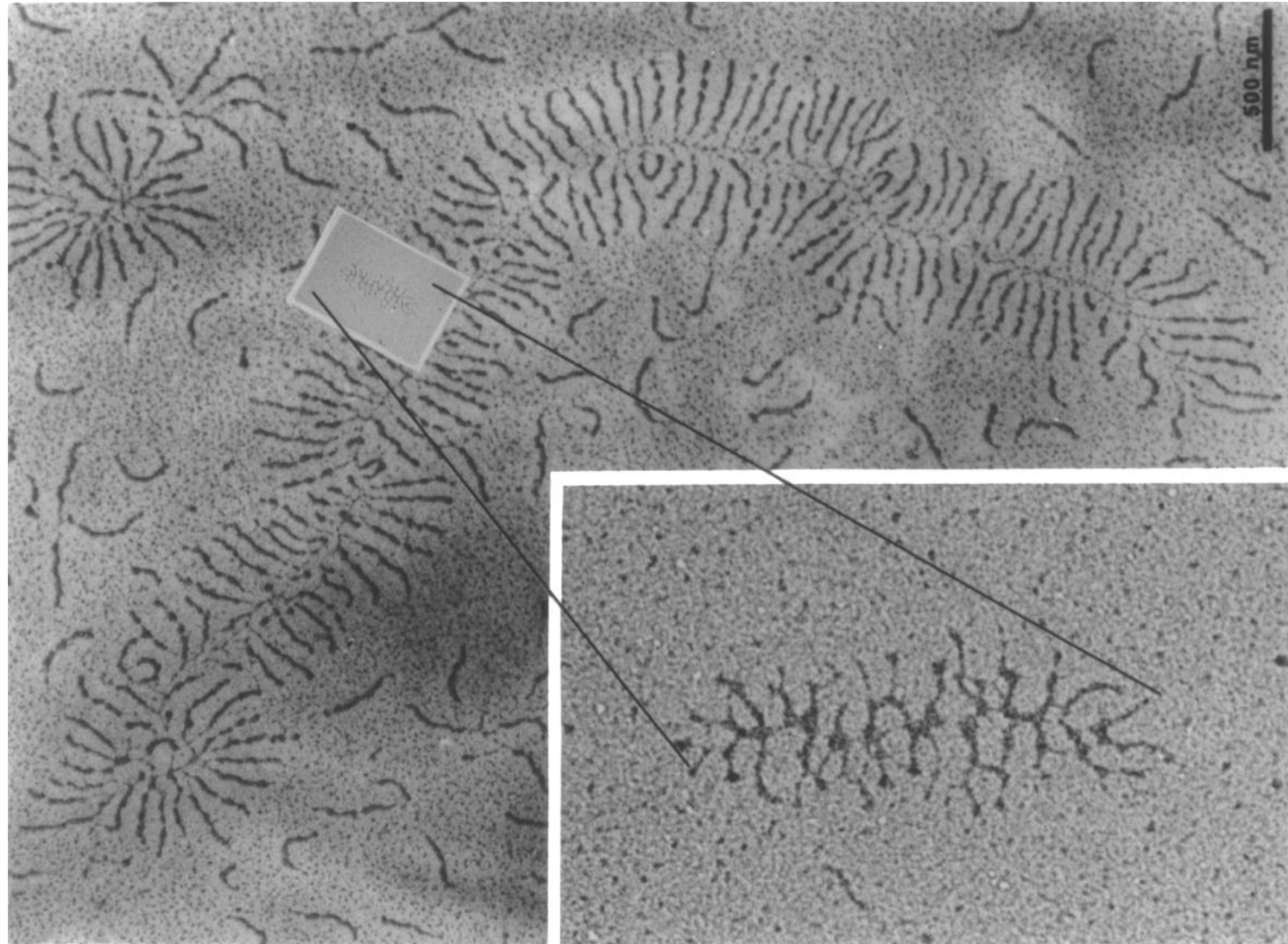

Aggrecan Aggregate, HA & Link Protein

Glycerol spraying-rotary shadow EM

Supramacromolecular complexes (5-8 μm length)

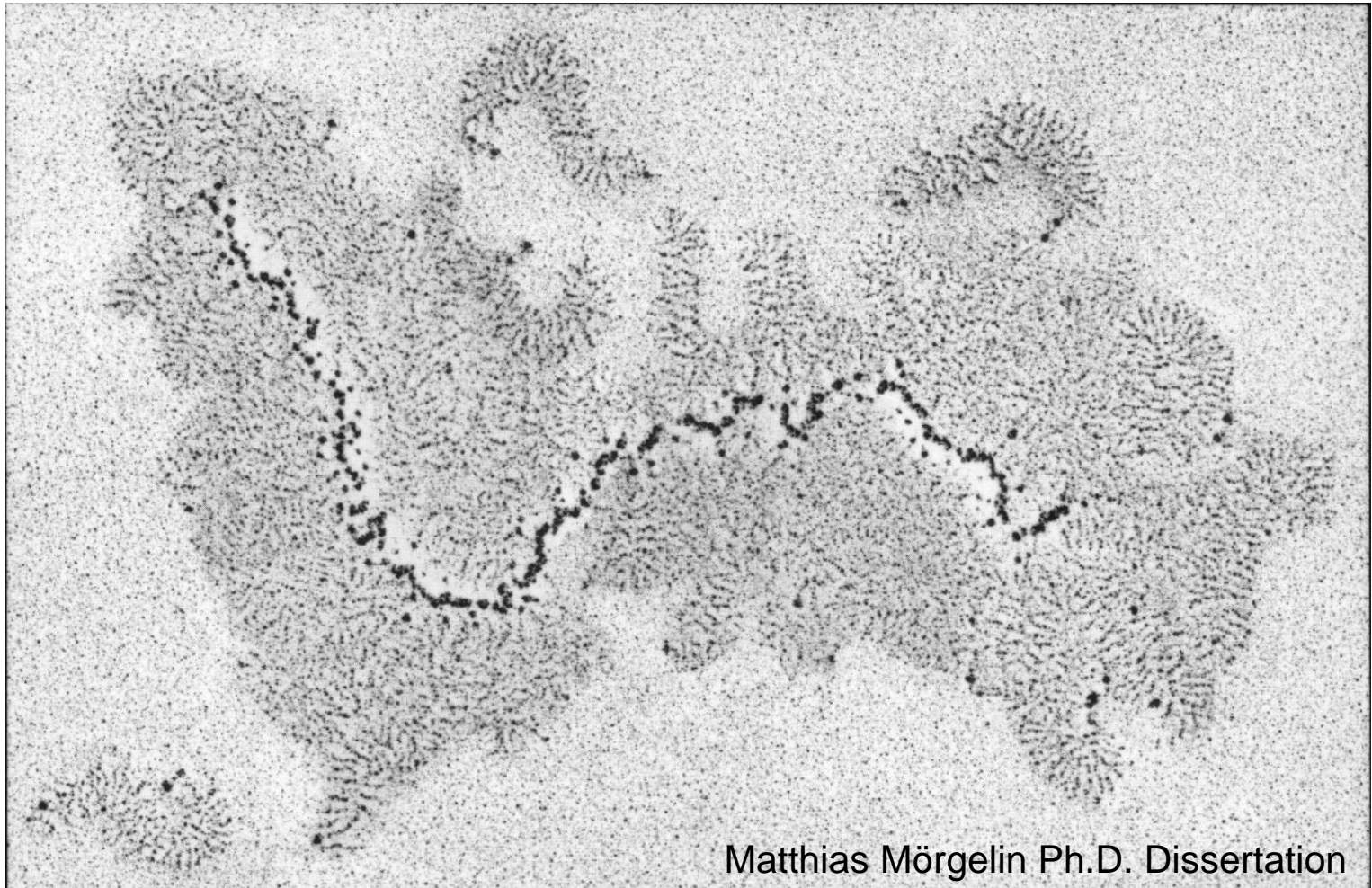

Chondrocyte

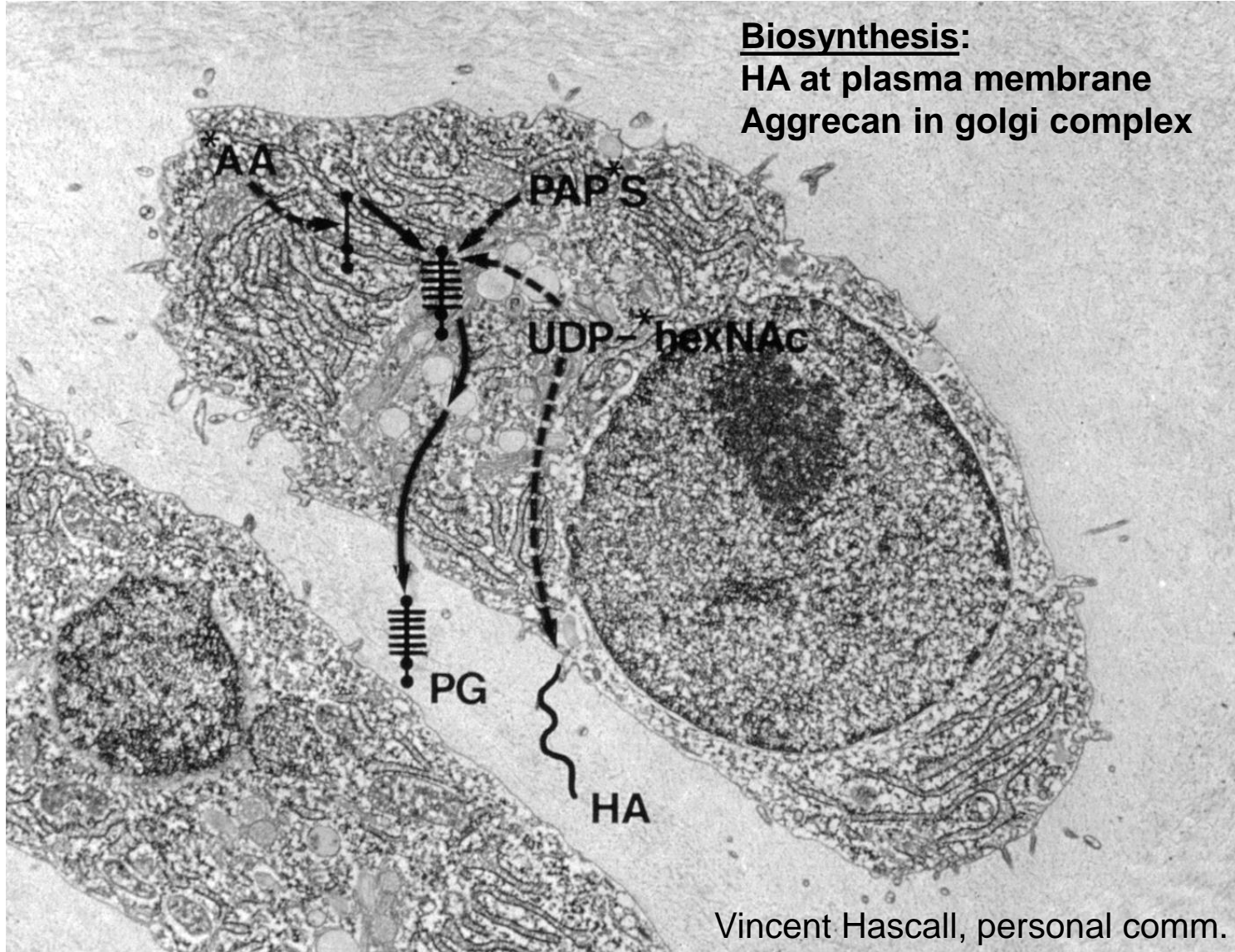

Chondrocytes Secrete Aggrecan in a Pre-Compressed State

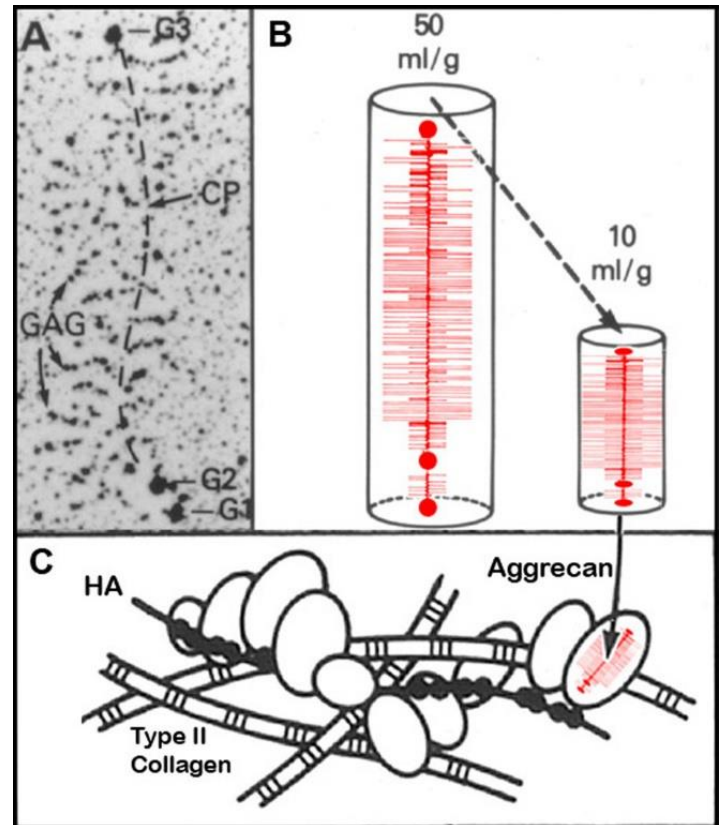
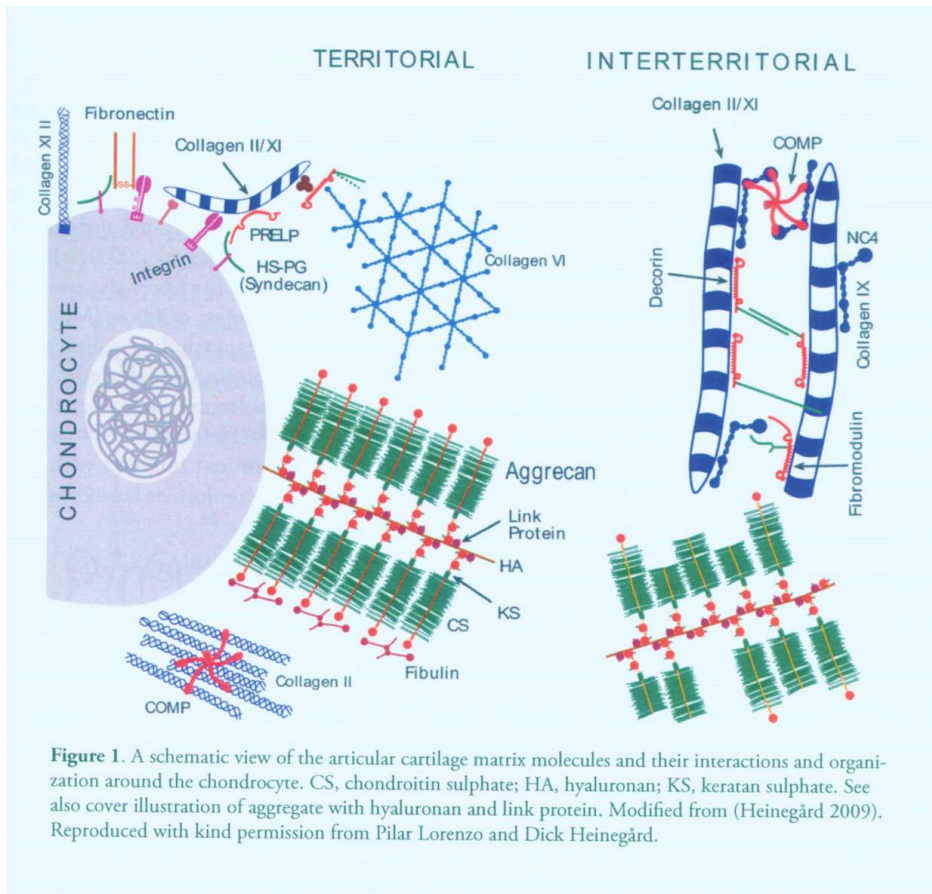

Knee Joint Osteoarthritis

Radiographic imaging of Joint Space Width



Acta Orthop. 89, 197-203, 2018

Knee Joint Osteoarthritis

Aggrecan Proteoglycan Loss with Disease Progression

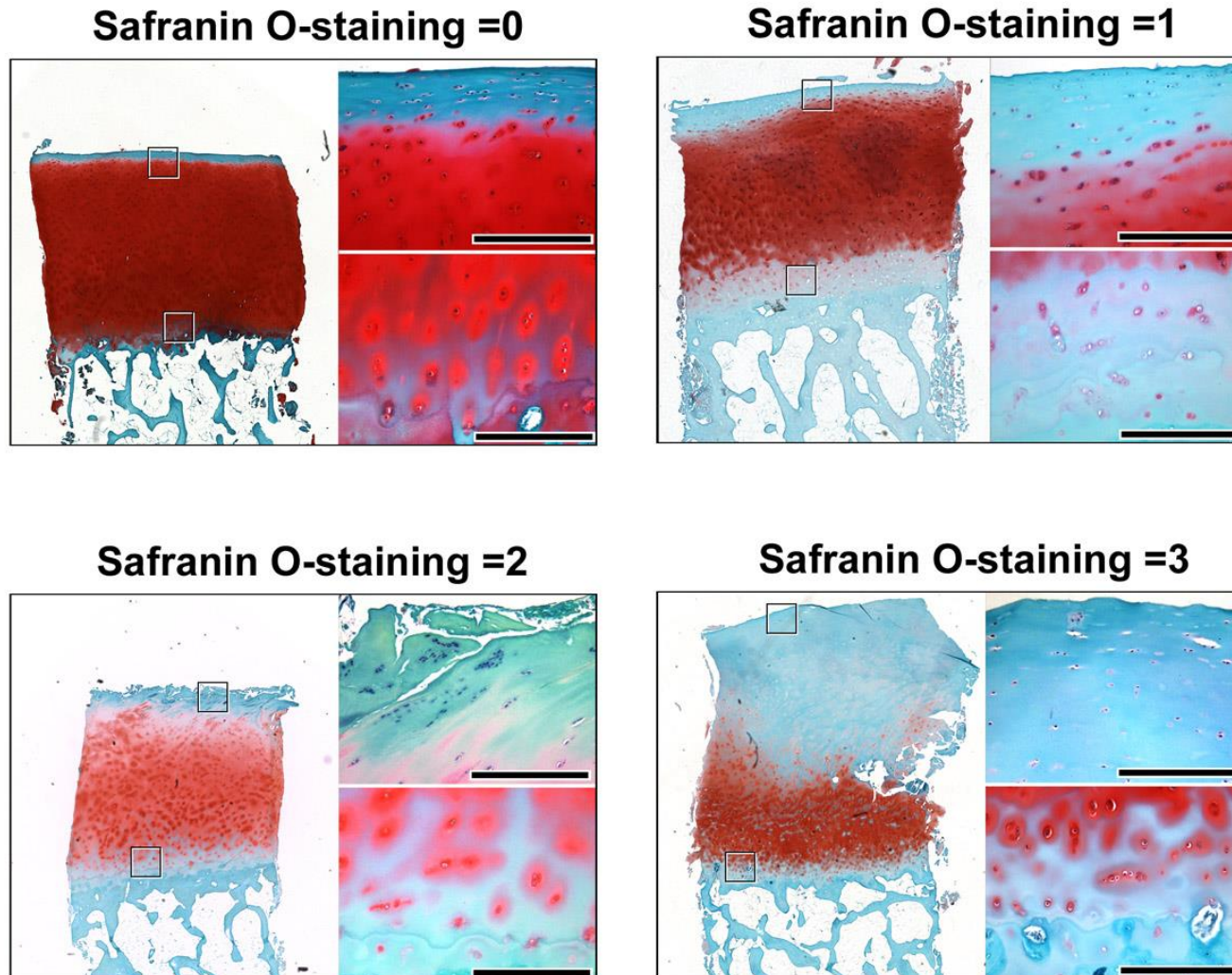

Acta Orthop. 89, 197-203, 2018

Small Leucine Rich Proteoglycans (SLRPs)

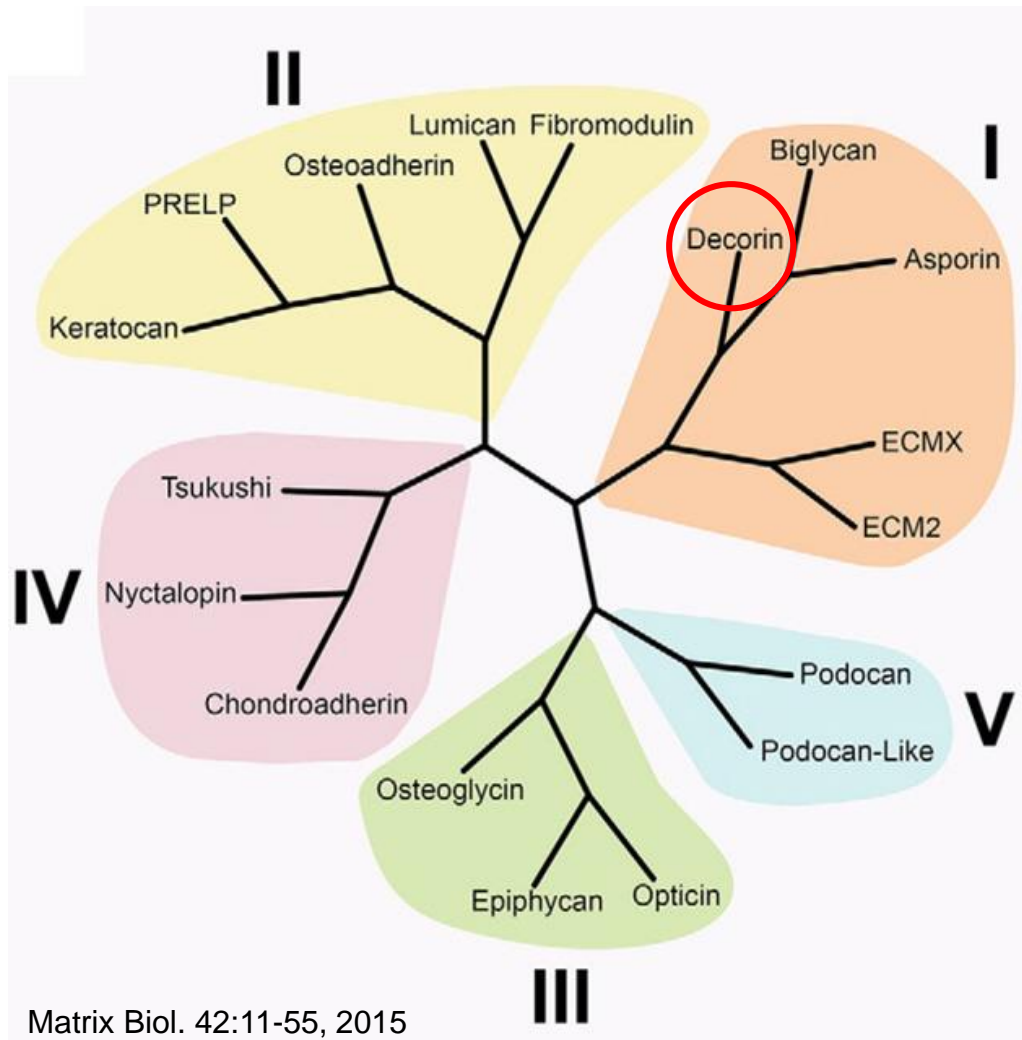

Decorin

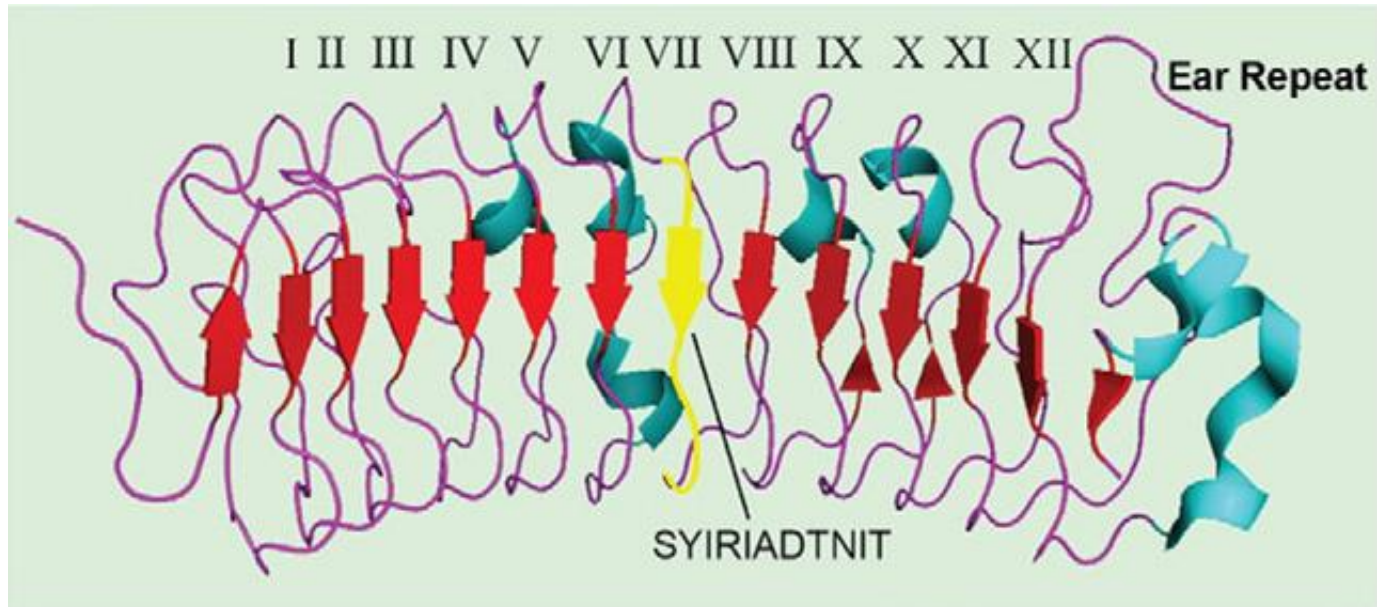
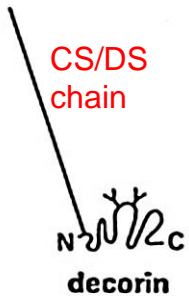

Matrix Biol. 42:11-55, 2015

Decorin

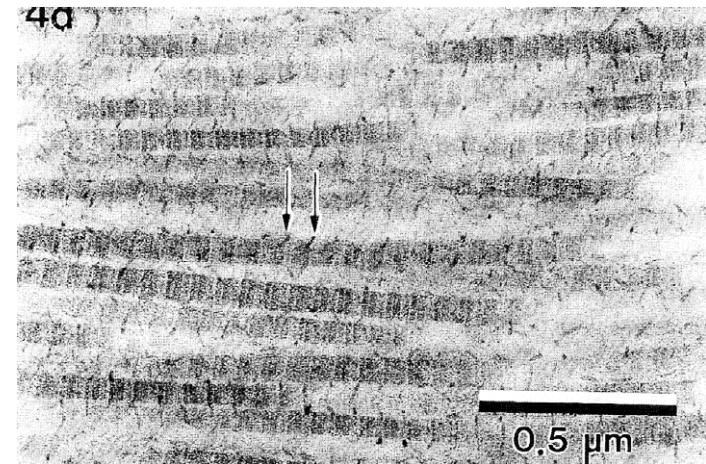
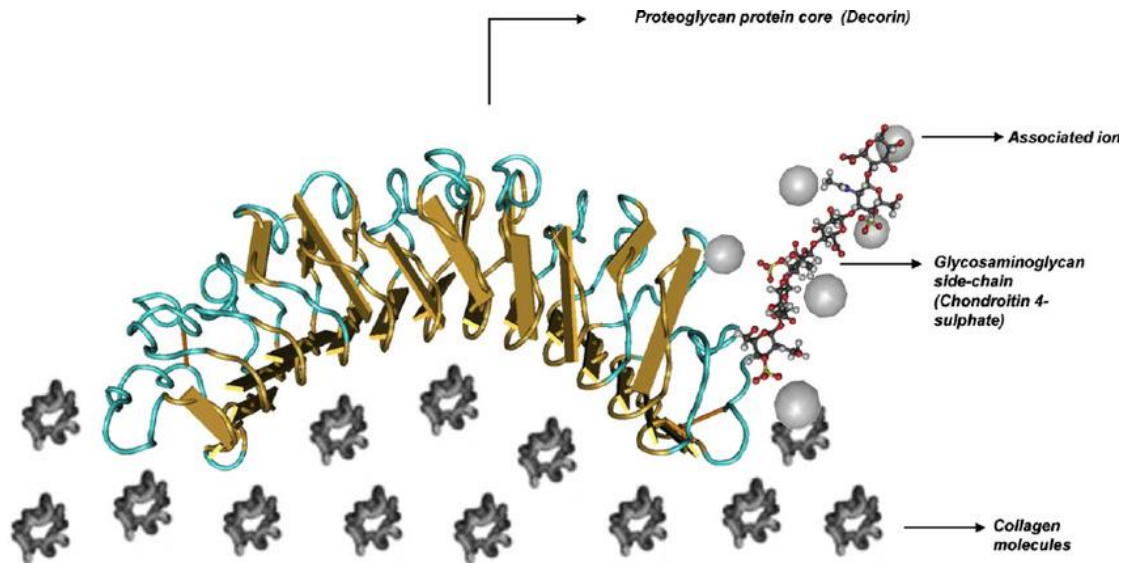

J Cell Biol. 136, 729–43, 1997

Decorin helps assemble collagen I fibers into proper orientation and packing density

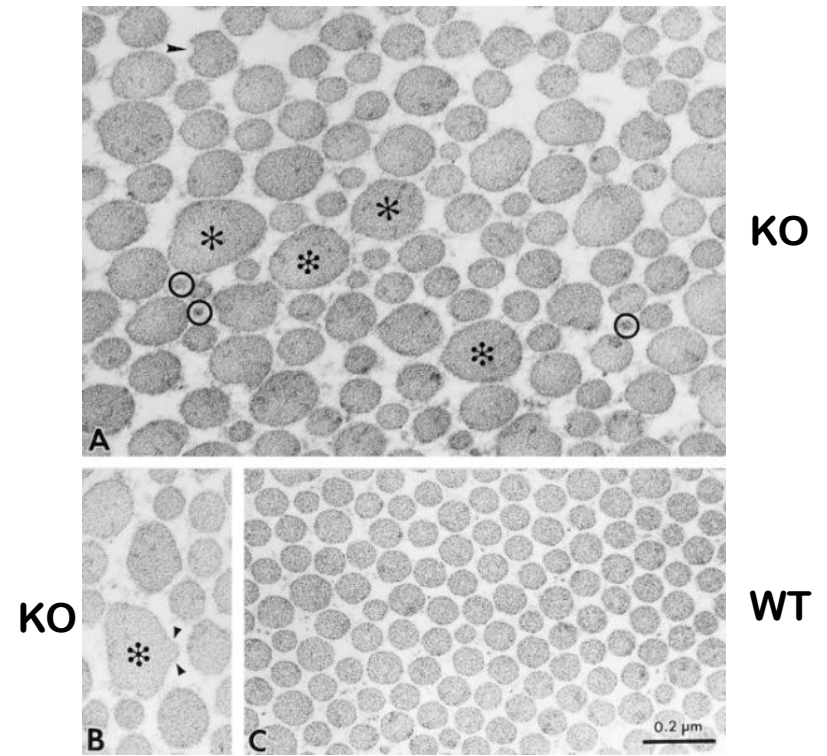
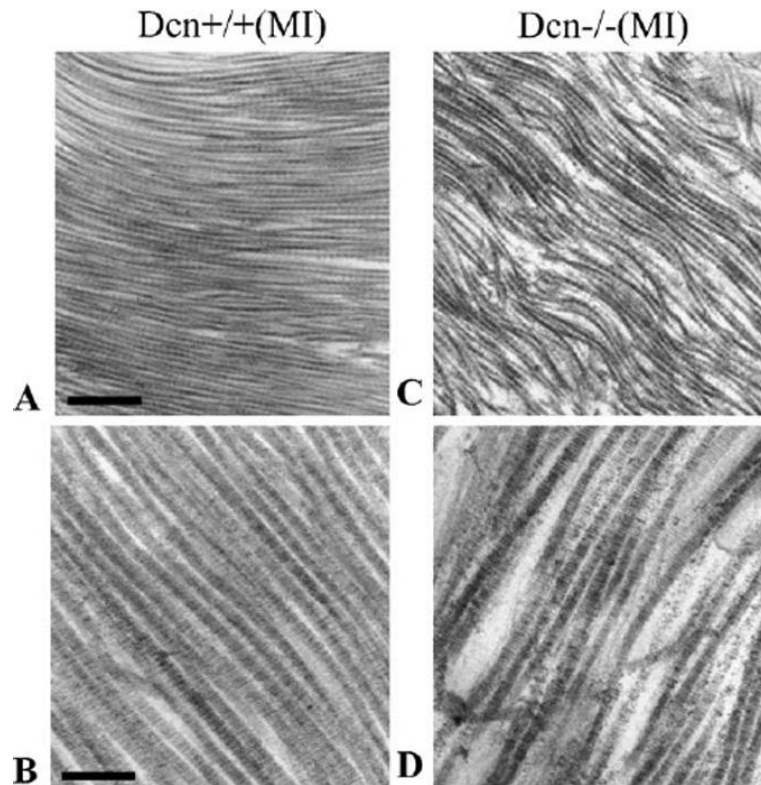

J Cell Biol. 136, 729–43, 1997

Chondrodystrophies Due to Sulfation Defects

1. Autosomal Recessive mutations in sulfate transporter

- **Diastrophic dysplasia (DTD)**
 - Short stature, joint dysplasia, normal lifespan
- **Atelosteogenesis type II (AOII)**
 - Perinatally lethal
- **Achondrogenesis type 1B (ACG-1B)**
 - Extremely short extremities and trunk

Chondrodystrophies Due to Sulfation Defects

2. Defective Synthesis of PAPS

- **Spondyloepimetaphyseal dysplasia**
 - Short, bowed legs, enlarged knee joints, degenerative joint disease
- **Brachymorphic mouse**
 - Growth disorder, short trunk & limbs, normal skull

BRACHYMORPHIC MOUSE (bm/bm)

Synthesis of sulfation cofactor, PAPS, (phosphoadenosinephosphosulfate) is impaired. In cells such as chondrocytes with high synthesis of sulfated proteoglycans, PAPS becomes limiting with resultant undersulfation of glycosaminoglycan chains (up to 15% in growth cartilages), and foreshortening of epiphyseal plates.

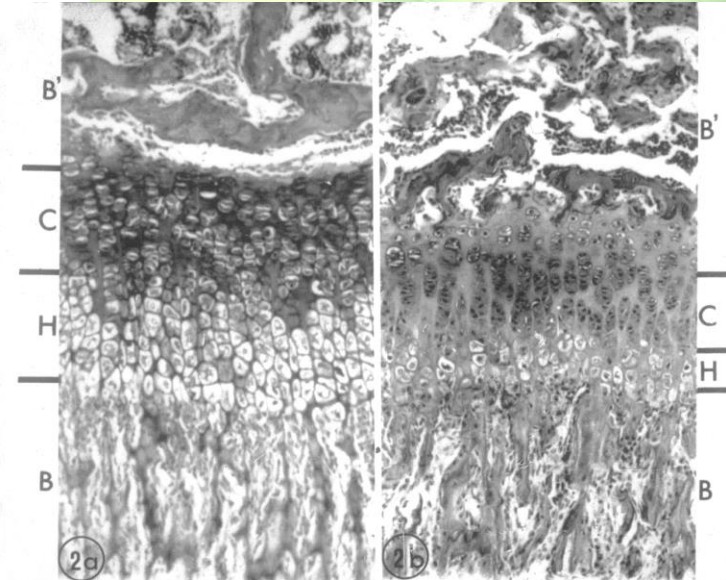
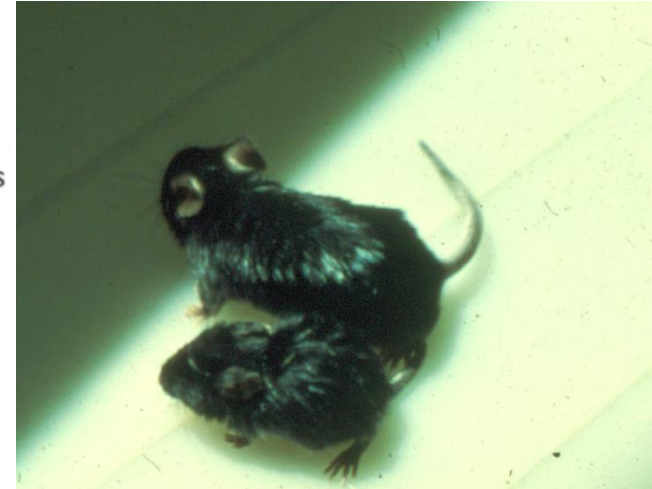
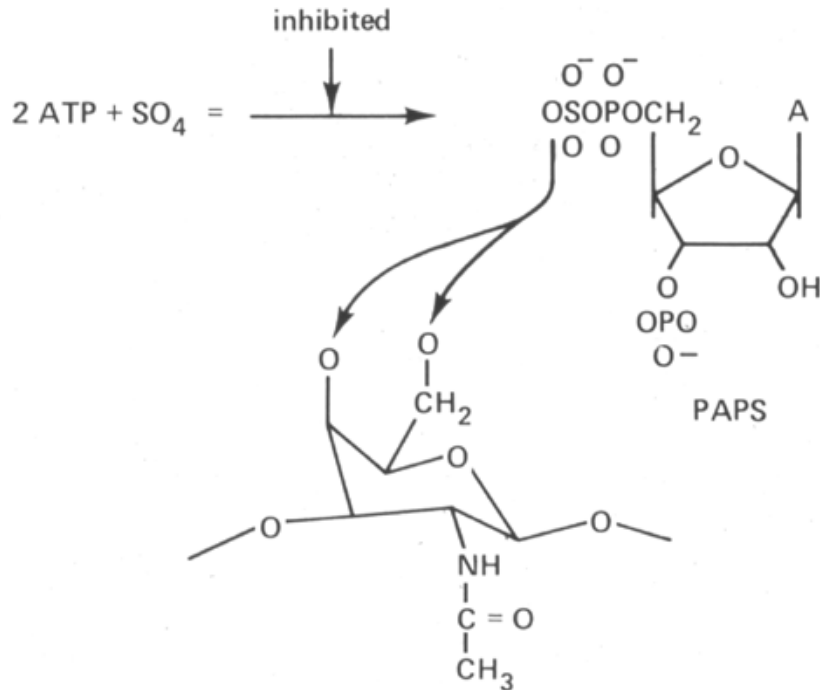

J Cell Biol. 73:287-99, 1977

Mucopolysaccharidoses

- **Group of inherited metabolic diseases caused by the absence or malfunctioning of enzymes needed to break down glycosaminoglycans (GAGs)**
- **Lysosomal storage diseases**
- **Over time, the partially degraded GAGs collect in the cells, blood, and connective tissues.**
- **Progressive, permanent, cellular damage that affects the individual's appearance, physical abilities, organ function, and, in most cases, mental development.**
- **1/25,000 live births (autosomal recessive, X-linked)**
- **Enzyme replacement therapy??**

Mucopolysaccharidoses

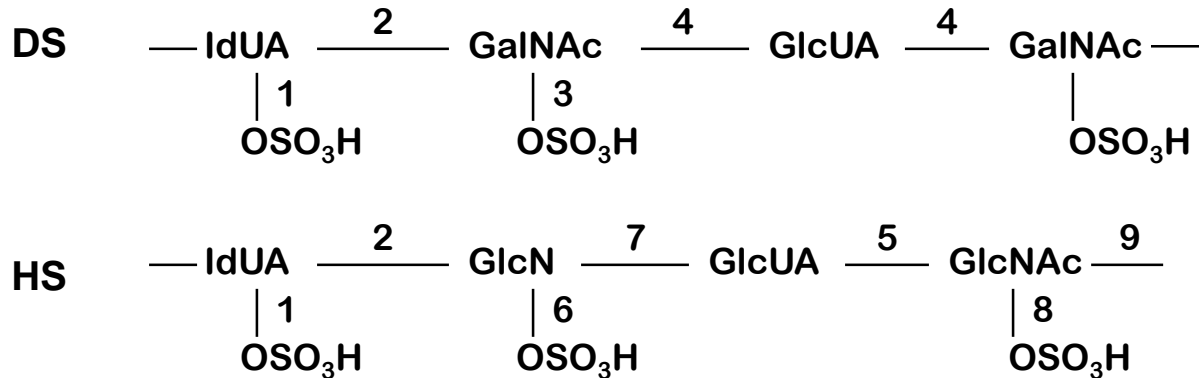

Syndrome	PG	Deficient Enzyme
Hunter's	HS	Iduronate sulfatase (1)
Hurler-Scheie	DS	α -L-Iduronidase (2)
Maroteaux-Lamy	HS/DS	<i>N</i> -acetylgalactosamine sulfatase (3)
Mucopolipidosis VII	HS/DS	β -Glucuronidase (4)

Mucopolysaccharidoses

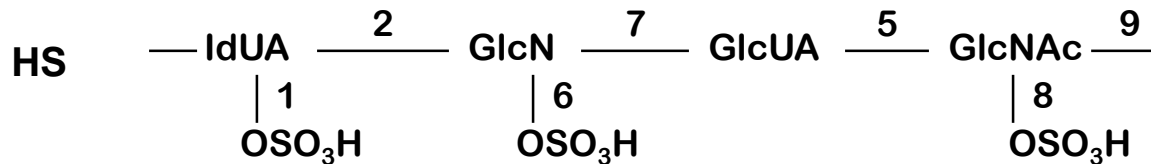
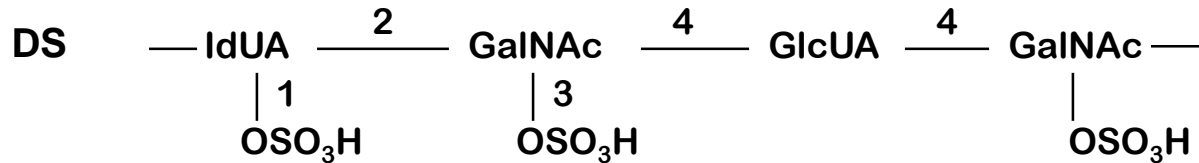

Syndrome	PG	Deficient Enzyme
Sanfilippo's type A	HS	Heparan sulfamidase (6)
Sanfilippo's type B	HS	<i>N</i> -acetyl-glucosaminidase (9)
Sanfilippo's type C	HS	Acetyl CoA:a-glucosaminide acetyl transferase
Sanfilippo's type D	HS	<i>N</i> -Acetylglucosamine 6-sulfatase (8)
Morquio's type A	KS/CS	Galactose-6-sulfatase
Morquio's type B	KS	β-Galactosidase

Classification of mucopolysaccharide storage diseases

Classification of Mucopolysaccharide Storage Diseases

Disorder (Syndromic Name)	Enzyme Defect	Facies	Neurologic	Dysostosis Multiplex	Corneal Clouding	Hepato-splenomegaly
MPS IH (Hurler)	α -L-Iduronidase	Coarse	Severe MR	+++	++++	+++
MPS IH/S (Hurler-Scheie)	α -L-Iduronidase	Coarse	\pm MR CTS	++	+++	++
MPS IS (Scheie)	α -L-Iduronidase	Normal	CTS	+	++	\pm
MPS IIA (Hunter)	Iduronate-2-sulfatase	Coarse	Severe MR	+++	O	++
MPS IIB (Hunter)	Iduronate-2-sulfatase	Normal-to-mild coarsening	CTS	+ to ++	O	+
MPS IIIA (Sanfilippo)	Heparan N-sulfatase	Mild coarsening	Severe MR	\pm	\pm	O
MPS IIIB (Sanfilippo)	α -N-Acetylglucosaminidase	Mild Coarsening	Severe MR	\pm	\pm	O
MPS IIIC (Sanfilippo)	Acetyl-CoA: α -glucosaminide acetyltransferase	Mild Coarsening	Severe MR	\pm	\pm	O
MPS IIID (Sanfilippo)	N-Acetylglucosamine 6-sulfatase	Mild Coarsening	Severe MR	\pm	\pm	
MPS IVA (Morquio)	N-Acetylgalactosamine-6-sulfatase	Mildly dysmorphic	Cervical compression myelopathy	+++; absent or hypoplastic odontoid process	\pm	O
MPS IVB (Morquio)	β -Galactosidase					
MPS VI (Maroteaux-Lamy)	Acetyl-CoA: α -glucosaminide acetyltransferase	Mild-to-moderate coarsening	\pm MR	++	++ to +++	\pm
MPS VII (Sly)	N-Acetylglucosamine 6-sulfatase	Mild coarsening	Severe MR	++	Unknown	+
MPS IX	Hyaluronidase		Polyarthropathy			

Hurler's Syndrome (MPS I)

- Deficient α -L-iduronidase (DS GAGS)
- Thick, coarse facial features with low nasal bridge
- Progressive CNS deterioration, progressive mental retardation
- Dwarfism, joint problems, abnormal bones in the spine
- Cloudy corneas
- Deafness
- Heart valve problems
- Death often by the age of 10

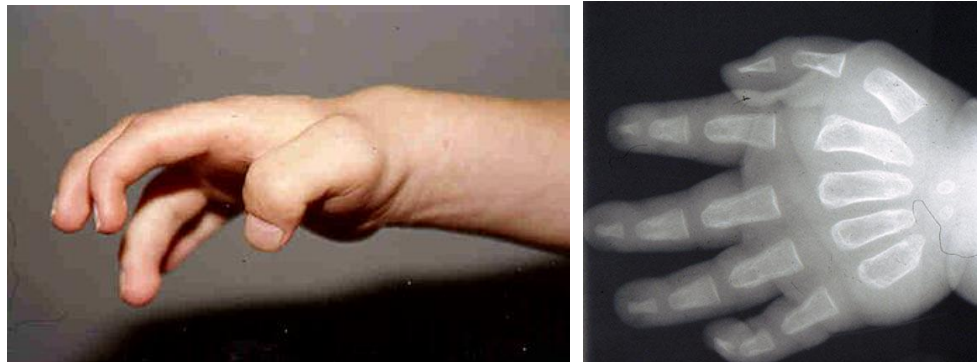
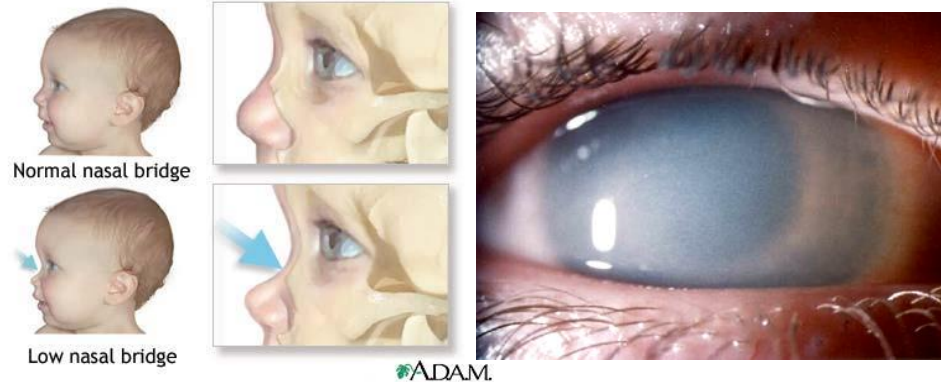

Hurler's Syndrome (MPS I): Treatment

- **Bone Marrow Transplant / Cord Blood Transplant**
- **Enzyme Replacement Therapy**
 - Somewhat effective for reducing non-neurological symptoms and pain

Hunter's Syndrome (MPS II)

- X-linked, iduronate 2-sulfatase deficiency
- GAGs derived from HS & DS deposit in tissues & excessive excretion in urine
- Dwarfism, abnormal bone formation, abnormal facies, hepatosplenomegaly, deafness, progressive cardiovascular problems, limited joint mobility, neurocognitive degeneration
- MPS IIA - progressive mental retardation and physical disability, death by age 15
- MPS IIB - mild form, survival to adulthood, minimal mental impairment



Clinical appearance of Morquio disease type A

Mucopolysaccharide storage disorders



Proteoglycans, Hyaluronan & Glycosaminoglycans

- **Glycoprotein vs. Proteoglycan**
- **Glycosaminoglycan (GAG) classes**
 - Mucopolysaccharides (aka GAGs)
- **GAG synthesis locations**
- **Proteoglycan classes**
- **GAG degradation**
 - Osteoarthritis
 - Mucopolysaccharidoses